



POLYURETHANE MACHINERY CORPORATION



Classic PH-25/PHX-25 Proportioner

Hydraulic, Heated, Plural Component
Proportioner

For spraying Polyurethane Foam and
Coatings

For Professional Use Only

Not approved for use in explosive
atmosphere locations

Manual

Ref. # MN-04004

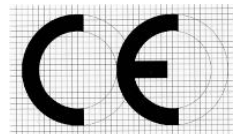

REV 1.0

Polyurethane Machinery Corp.

Corporate: 1 KOMO Drive, Lakewood, NJ 08701

Manufacturing: 2 KOMO Drive, Lakewood, NJ 08701

Phone: 732-415-4400

Fax: 732-364-4025

<http://www.polymac-usa.com>



Before installing the PH Series Proportioner and start-up, carefully read all the technical and safety documentation included in this manual. Pay special attention to the information in order to know and understand the operation and the conditions of use of the PH Series Proportioner. All of the information is aimed at improving user safety and avoiding possible breakdowns from the incorrect use of the PH Series Proportioner



Classic PH/PHX-25

TABLE OF CONTENTS

WARRANTY	4
SAFETY AND HANDLING	6
CHARACTERISTICS	8
PRINCIPAL HEATING SYSTEM	8
HOSE HEATING SYSTEM	8
DOUBLE ACTING OPPOSED PISTON METERING PUMPS	8
PRESSURE BALANCE CONTROL SYSTEM	9
TECHNICAL SPECIFICATIONS	10
ELECTRICAL.....	10
MECHANICAL	10
DESCRIPTION	11
INSTALLATION	15
PROPORTIONER PURGING	21
PRESSURE BALANCE CONTROL	22
OPERATION.....	22
DIGITAL TEMPERATURE CONTROLLER	23
START-UP	24
SHUT-DOWN	26
TROUBLESHOOTING	27
HEATERS.....	28
HYDRAULIC DRIVE SYSTEM.....	31
METERING PUMP LINE.....	33
HOSE HEATING	37
PRESSURE BALANCE CONTROL	40
MAINTENANCE	41
INLET MATERIAL SCREENS.....	42
ISO LURICATION SYSTEM	43
HYDRAULIC DRIVE SYSTEM.....	43
METERING PUMP LINE.....	44
METERING PUMP REMOVAL	45
MATERIAL HEATER	46



Classic PH/PHX-25

REPLACEMENT KITS	48
HYDRAULIC OIL SPECIFICATIONS	52
PART IDENTIFICATION	53
PUMPLINE ASSEMBLY	53
HYDRAULIC CYLINDER COMPLETE	54
HYDRAULIC CYLINDER ASSEMBLY	55
HYDRAULIC SEAL ASSEMBLY	56
HYDRAULIC PISTON ASSEMBLY	57
“R” PUMP ASSEMBLY; SIZE 120 & 80	58
“A” PUMP ASSEMBLY; SIZE 120.....	59
“A” PUMP ASSEMBLY; SIZE 80.....	60
PISTON ASSEMBLY	61
PUMP BASE ASSEMBLY	62
HEATER ASSEMBLY	63
PRESSURE TRANSDUCER ASSEMBLY	66
TRANSFORMER COVER ASSEMBLY	67
Y-STRAINER ASSEMBLY	69
FRAME/TANK ASSEMBLY	70
MOTOR LINE ASSEMBLY	72
TOP LEVEL ASSEMBLY	73
LUBE BOTTLE COMPONENTS	75
HOSES	76
MANUAL REVISIONS	77

*Picture on cover is shown with **OPTIONAL** inlet monitoring kit.



Classic PH/PHX-25

WARRANTY

Polyurethane Machinery Corporation (hereinafter “PMC”) provides this **LIMITED WARRANTY** (hereinafter “Warranty”) to the original purchaser (hereinafter “Customer”) covering this equipment and the original PMC manufactured accessories delivered with the equipment (hereinafter “Product”) against defects in material or workmanship of the Product (hereinafter “Defect” or “Defective”) for a period of one (1) year from the date of first purchase as shown on the original PMC invoice (hereinafter “Warranty Period”).

If during the Warranty Period under normal use, the Product is suspected by Customer to be Defective in material or workmanship, it is Customer’s responsibility to contact PMC and return the Product to PMC as directed by PMC, freight prepaid. If PMC determines that the Product is Defective and that such Defect is covered by this Warranty, PMC will credit Customer for the reasonable freight charges incurred by Customer in returning the Defective Product to PMC, and PMC (or its authorized agent) will, at PMC’s option, repair or replace the Product, subject to the following:

Original Invoice: The original invoice must be kept as proof of the date of first sale and the Product serial number. The Warranty does not cover any Product if the Original Invoice appears to have been modified or altered, or when the serial number on the Product appears to have been altered or defaced.

Product Maintenance: It is the Customer’s responsibility to maintain the Product properly. See your maintenance schedule and owner’s manual for details. The Warranty does not cover an improperly maintained Product.

Non-PMC Components and Accessories: Non-PMC manufactured components and accessories that are used in the operation of the Product are not covered by this Warranty. Such components and accessories shall be subject to the warranty offered to the Customer, if any, by the original manufacturer of such component or accessory.

Other Warranty Exclusions: The Warranty does not cover any Product that PMC determines has been damaged or fails to operate properly due to misuse, negligence, abuse, carelessness, neglect, or accident. By way of example only, this includes:

Normal wear and tear.

- Improper or unauthorized installation, repair, alteration, adjustment or modification of the product.
- Use of heating devices, pumping equipment, dispensers, or other parts or accessories with the product that have not been approved or manufactured by PMC.
- Failure to follow the operating instructions and recommendations provided by PMC.
- Cosmetic damage.
- Fire, flood, “acts of God,” or other contingencies beyond the control of PMC.



Classic PH/PHX-25

THE WARRANTY DESCRIBED HEREIN IS THE EXCLUSIVE REMEDY FOR THE CUSTOMER AND IS IN LIEU OF ALL OTHER WARRANTIES, EXPRESS, IMPLIED, STATUTORY OR OTHERWISE, AND THE IMPLIED WARRANTIES OF MERCHANTABILITY AND FITNESS FOR A PARTICULAR PURPOSE AND ALL OTHER WARRANTIES ARE HEREBY DISCLAIMED. TO THE FULLEST EXTENT PERMITTED BY LAW, PMC SHALL NOT BE RESPONSIBLE, WHETHER BASED IN CONTRACT, TORT (INCLUDING, WITHOUT LIMITATION, NEGLIGENCE), WARRANTY OR ANY OTHER LEGAL OR EQUITABLE GROUNDS, FOR ANY CONSEQUENTIAL, INDIRECT, INCIDENTAL, LOST PROFITS, SPECIAL, PUNITIVE OR EXEMPLARY DAMAGES, WHETHER TO PERSON OR PROPERTY, ARISING FROM OR RELATING TO THE PRODUCT, EVEN IF PMC HAS BEEN ADVISED OF THE POSSIBILITY OF SUCH LOSSES OR DAMAGES.

Non-Warranty Service by PMC: If PMC determines that the suspected Defect of the Product is not covered by this Warranty, disposition of the Product will be made pursuant to the terms and conditions of PMC's written estimate on a time and materials basis.

Continuing Warranty for Products Repaired or Replaced under Warranty: Following the repair or replacement of a Product covered by this Warranty, such Product will continue to be subject to the original Warranty for the remainder of original Warranty Period or for three (3) months from the repair or replacement date, whichever is longer.

No Rights Implied: Nothing in the sale, lease or rental of any Product by PMC shall be construed to grant any right, interest or license in or under any patent, trademark, copyright, trade secret or other proprietary right or material owned by anyone; nor does PMC encourage the infringement of same.

Exclusive Warranty: This writing is the final, complete, and exclusive expression of the Warranty covering the Product. Any statements made by PMC, its employees or agents that differ from the terms of this Warranty shall have no effect. It is expressly understood that Customer's acceptance of this Warranty, by performance or otherwise, is upon and subject solely to the terms and conditions hereof, and any additional or different terms and conditions proposed or expressed by Customer or anyone, whether in writing or otherwise, are null and void unless specifically agreed to in writing by an Officer of PMC.



Classic PH/PHX-25

SAFETY AND HANDLING

This chapter contains important information on the safety, handling and use of your *Classic* PH Series Proportioner.



Before installing the PH Series Proportioner and start-up, carefully read all the technical and safety documentation included in this manual. Pay special attention to the information to know and understand the operation and the conditions of use of the PH Series Proportioner. All of the information is aimed at enhancing User Safety and avoiding possible breakdowns derived from the incorrect use of the PH Series Proportioner.

WARNING! Presents information to alert of a situation that might cause serious injuries if the instructions are not followed.

CAUTION! Presents information that indicates how to avoid damage to the Proportioner or how to avoid a situation that could cause minor injuries.

NOTE! Is relevant information of a procedure being carried out.

Careful study of this manual will enable the operator to know the characteristics of the PH Series Proportioner and the operating procedures. By following the instructions and recommendations contained herein, you will reduce the potential risk of accidents in the installation, use or maintenance of the PH Series Proportioner; you will provide a better opportunity for incident-free operation for a longer time, greater output and the possibility of detecting and resolving problems quickly and simply.

Keep this Operations Manual for future consultation of useful information at all times. If you lose this manual, ask for a new copy from your PMC Distributor or go online and visit our web site at www.polymac-usa.com.



Classic PH/PHX-25

The *Classic* PH Series Proportioner has been designed and built for the application of polyurea chemical systems, polyurethane foam chemical systems and some two-component epoxy systems.

WARNING! The design and configuration of the PH Series Proportioner does not allow its use in potentially explosive atmospheres or the pressure and temperature limits described in the technical specifications of this manual to be exceeded.

Always use liquids and solvents that are compatible with the unit. If in doubt, consult your PMC Distributor.

When working with the PH Series Proportioner, it is recommended that the operator wear suitable clothing and elements of personal protection, including, without limitation, gloves, protective goggles, safety footwear and face masks. Use breathing equipment when working with the PH Series Proportioner in enclosed spaces or in areas with insufficient ventilation. The introduction and follow-up of safety measures must not be limited to those described in this manual. Before starting up the PH Series Proportioner, a comprehensive analysis must be made of the risks derived from the products to be dispensed, the type of application and the working environment.



To prevent possible injury caused by incorrect handling of the raw materials and solvents used in the process, carefully read the Material Safety Data Sheet (MSDS) provided by your supplier.

Deal with the waste caused according to current regulations.

To avoid damage caused by the impact of pressurized fluids, do not open any connection or perform maintenance work on components subject to pressure until the pressure has been completely eliminated.

Use suitable protection when operating, maintaining or being present in the area where the equipment is functioning. This includes, but is not limited to, the use of protective goggles, gloves, shoes and safety clothing and breathing equipment.

The equipment includes components that reach high temperatures and can cause burns. Hot parts of the equipment must not be handled or touched until they have cooled completely.

To prevent serious injury through crushing or amputation, do not work with the equipment without the safety guards installed on the moving parts. Make sure that all the safety guards are correctly reinstalled at the end of the repair or maintenance work of the equipment.



Classic PH/PHX-25

CHARACTERISTICS

The *Classic* PH-25 Proportioner has been designed and built for the application of polyurea chemical systems, polyurethane foam chemical systems and some specific two-component epoxy systems.

PRINCIPAL HEATING SYSTEM

The Proportioner consists of two (2) independent Material Heaters without internal seals. Each Heater has four (4) Heating Elements rated 1,000, 1,250 or 1,500 watts each giving the Proportioner a total heat of 8,000, 10,000 or 12,000 watts and the necessary control and safety components for their precise operation. The Material Heater design allows a temperature differential (ΔT) of 90° F (32° C) and material application temperatures of up to 190° F under normal ambient temperatures.

HOSE HEATING SYSTEM

The system is designed with a 3 KVA (90 V) Isolation Transformer that enables effective heating of up to a total hose length of 310 feet (94 Meters). The system includes an innovative hose heating concept in which the continuous braid tinned-copper jacket is distributed evenly around the circumference of the hose providing a uniform heating watt density and precise control of the material application temperature. This hose heating element design is extremely resistant to fatigue failure.

100% circumferential coverage produces the most uniform distribution of heat available.

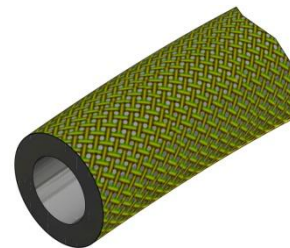

DOUBLE ACTING OPPOSED PISTON METERING PUMPS

The opposed double acting Pump Line is driven by a dual rod Hydraulic Cylinder. The in-line pump system with opposed piston pumps provides a constant volume and guarantees uniform pressures in both directions of pump movement. Different sized pumps allow for various volumetric ratios to be achieved (1:4 to 1:1 to 4:1) between the chemical components used in the process.



Classic PH/PHX-25

PRESSURE BALANCE CONTROL SYSTEM

The Pressure Balance Control (PBC) system provides better control over a chemical pressure imbalance. When the system is turned off, the Proportioner will perform as if there is no PBC system and will continue pumping material. When the system is turned on, it will continually monitor the pressure between the two chemicals (known as the **pressure differential**). If the pressure differential becomes equal to or greater than the **maximum allowable pressure differential**, the pumps will be shut off.

The Pressure Balance Control system can be simplified into a logic box diagram with inputs and outputs. There are five inputs: the power supply from the main console, the pressure readings from each chemical, the maximum pressure, and the maximum allowable pressure differential. Inside the logic box, the actual pressure differential of the chemicals is compared to the maximum allowable pressure differential. Depending on the circumstances of all five inputs, there are only two possible outputs: either the pumps will continue to pressurize and move material, or the pumps will shut off and flow will be lost.

Logic Box Representation





Classic PH/PHX-25

TECHNICAL SPECIFICATIONS

ELECTRICAL

Main Voltage: _____ **3 x 208-230V, 50/60Hz**

Electrical Consumption: (2 x 4 kW Heaters) _____ 27 A @ 3 x 230V

Electrical Consumption: (2 x 5 kW Heaters) _____ 35 A @ 3 x 230V

Electrical Consumption: (2 x 6 kW Heaters) _____ 43 A @ 3 x 230V

Main Voltage: _____ **1 x 208-230V, 50/60Hz**

Electrical Consumption: (2 x 4 kW Heaters) _____ 60 A @ 1 x 230V

Electrical Consumption: (2 x 5 kW Heaters) _____ 70 A @ 1 x 230V

Electrical Consumption: (2 x 6 kW Heaters) _____ 80 A @ 1 x 230V

Material Heater Power: (2 x 4 kW) _____ 8 kW

Material Heater Power: (2 x 5 kW) _____ 10kW

Material Heater Power: (2 x 6 kW) _____ 12kW

Hose Transformer Power: _____ 3 KVA (90 V)

Electrical Motor Power: _____ 3 HP



CAUTION! Inside the console is a Terminal Strip for connecting the main power (wire not supplied) to the PH Series Proportioner. This electrical connection must be made only by a qualified electrician.

MECHANICAL

Maximum working pressure (with 120 pumps): _____ 2,000 psi (138 Bar)

Maximum working pressure (with 80 pumps): _____ 3,000 psi (207 Bar)

Maximum production ratio 1:1 (with 120 pumps): _____ 25 lb/min (12.5kg/min)

Maximum production ratio 1:1 (with 80 pumps): _____ 1.4 gpm (5.6 lpm)

Minimum production: _____ 2 lb/min (1kg/min)

Maximum hose length: _____ 310 ft (93 m)

Approximate weight (Hydraulic Tank empty): _____ 420 lbs (210 kg)

Approximate weight (Hydraulic Tank full @ 20 gal, 8 liters): _____ 594 lbs (297 kg)

Dimensions: _____ 30in W x 26in D x 45in H

_____ (76cm W x 66cm D x 114cm H)



Classic PH/PHX-25

DESCRIPTION

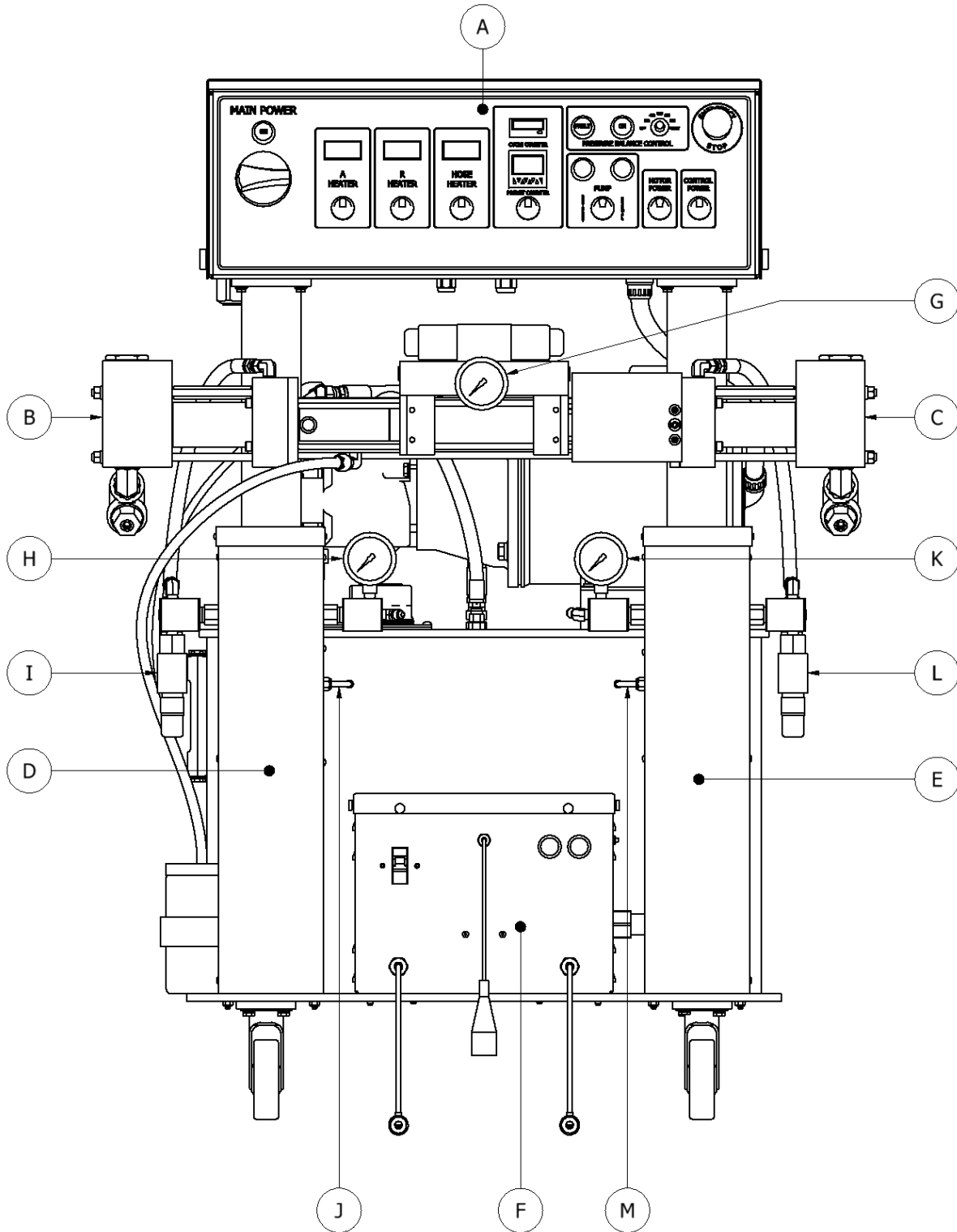



Classic PH/PHX-25

A. Control Panel

Controls and regulates the operation of the PH Series Proportioner.

B. Isocyanate (Iso, A) Metering Pump

Meters the Isocyanate material.

C. Polyol (Poly, R) Metering Pump

Meters the Polyol material.

D. Isocyanate (Iso, A) Heater

Heats the incoming Isocyanate to a temperature set by the operator.

E. Polyol (Poly, R) Heater

Heats the incoming Polyol to a temperature set by the operator.

F. Hose Heating Transformer

Supplies the required voltage for material Heated Hoses.

G. Hydraulic Pressure Gage

Indicates the pressure in the Hydraulic Drive System.

H. Isocyanate (Iso, A) Pressure Gage

Indicates the pressure in the Isocyanate system.

I. Isocyanate (Iso, A) Safety Pressure Switch

Disables the pump circuit in the event of excessive pressure in the Isocyanate system.

J. Isocyanate (Iso, A) Thermocouple

Provides temperature information of the Isocyanate to its Temperature Controller.

K. Polyol (Poly, R) Pressure Gage

Indicates the pressure in the Polyol system.

L. Polyol (Poly, R) Safety Pressure Switch

Disables the pump circuit in the event of excessive pressure in the Polyol system.

M. Polyol (Poly, R) Thermocouple

Provides temperature information of the Polyol to its Temperature Controller.

N. Hydraulic Pressure Control

Allows the pressure of the hydraulic system to be increased or decreased. Turn clockwise to increase the pressure and counterclockwise to decrease. To regulate the pressure of the hydraulic system, the NORMAL or RETRACT Pump Switch position must be selected.

O. Isocyanate (Iso, A) Inlet Material Strainer

Screens (60 mesh) material from bulk supply.

P. Polyol (Poly, R) Inlet Material Strainer

Screens (60 mesh) material from bulk supply.

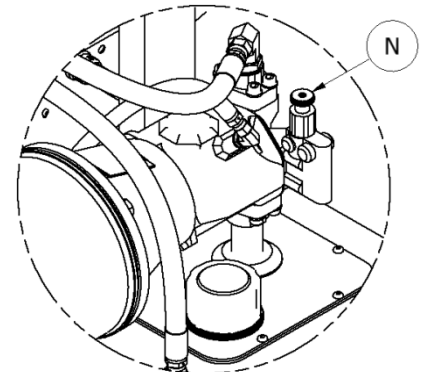



Classic PH/PHX-25

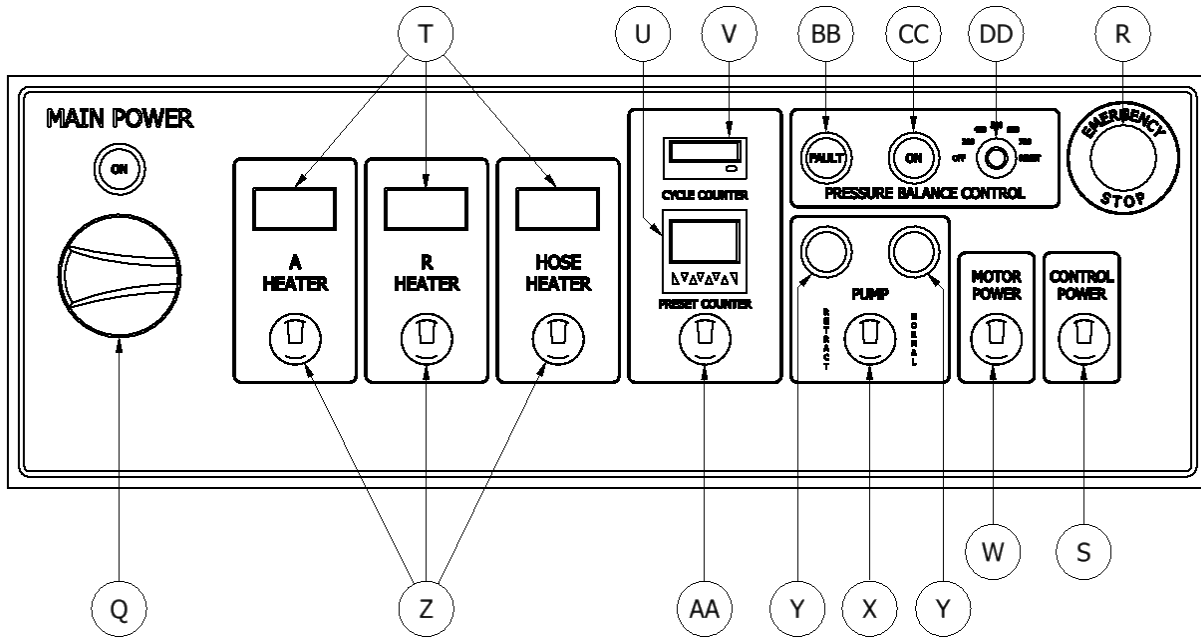

Control Panel

- Q. Main Power** - Turns ON and OFF main power to the control panel. It must be turned ON for any operation to be performed with the unit. When turned ON, the green pilot light will be lit.
- R. Emergency Stop** - Interrupts the PH Series control power circuit to stop all motion and heating.
- S. Control Power** - Turns ON and OFF the control power to the complete electrical circuit including Heaters and Hose Heater.
- T. Heater Temperature Zones, A (Iso), R (Poly), HOSE** - Turns ON and OFF power to the specific Heaters. See page 23 for detailed Temperature Controller instructions. The Hose Heater Controller automatically controls the Hose Heater only when using the TSU (Temperature Sensing Unit) probe.
- U. Count Down Counter**
Used to set the amount of cycles required to prevent the chemical drums from running dry, the machine will shut down when the preset cycles expires. There is an on/off switch to either activate this feature or deactivate and not use it.
- V. Cycle Counter** – Indicates the number of pump cycles to calculate material usage.

PUMP SIZE	CYCLES PER GALLON / 3.79 LITERS
120	16
80	24



Classic PH/PHX-25

- W. Motor Switch** - Turns ON and OFF the Electric/Hydraulic Motor. When turned ON the switch will be lit. In the event of an overload of the Motor, pilot light will turn OFF and Motor will stop.
- X. Pump Switch**
 - Off** - Removes power from the pump circuit. The directional indicator lights will not be lit.
 - Normal** - Activates the normal operation of the machine. When the switch is ON, the directional light corresponding to the stroke direction will light.
 - Retract** - Sets the Piston Rod of the Iso (A) metering pump to the retract position and prevents the crystallization of Iso (A) on the Piston Rod. Turn the switch to RETRACT position every time the unit is stopped by the operator (see Shut-Down, page 26).
- Y. Direction Indicator Light** - Indicates the direction of movement of the Metering Pumps. If excessive pressure occurs in the system, the pump circuit will be disabled and the directional lights will be OFF.
- Z. Heater Temperature Switch – A (Iso), R (Poly), HOSE** – Turns ON and OFF power to the specific Heaters and Hose.
- AA. Auto Shut Down Switch** - Turns ON and OFF power to the Auto Shut Down unit.
- BB. Pressure Balance Control “FAULT” Light** – Indicates that the pressure differential is equal to or greater than the maximum allowable pressure differential.
- CC. Pressure Balance Control “ON” Light** – Indicates that the Pressure Balance Control system is on and functioning.
- DD. Pressure Balance Control Knob** – Used to set the maximum allowable pressure differential (in PSI) between the A (Iso) and R (Poly) pumps. See page 22 for more information.



Classic PH/PHX-25

INSTALLATION

WARNING! Use suitable protection and follow the recommendations in the Safety Information enclosed and provided by material suppliers when installing or working with the Proportioner.



Inside the console is a Terminal Strip for connecting the incoming power cable (not supplied). The electrical connection of the Proportioner must be carried out by a qualified electrician.

NOTE! To ensure the PH Series Proportioner works correctly, the electrical supply must meet the specifications indicated on the Serial Number Placard affixed to the Electrical Console.

CAUTION! Make sure the power cable is disconnected from the main power source before connecting to the Terminal Strip in the Console.

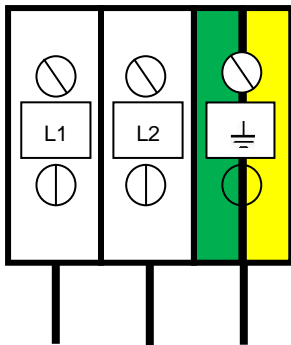

1 phase x 230 Volt

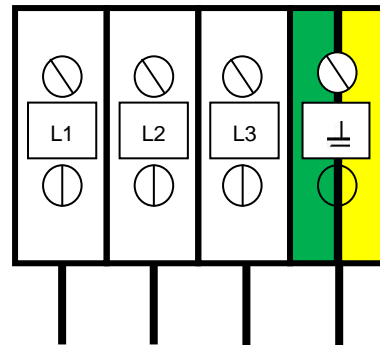

3 phase x 230 Volt

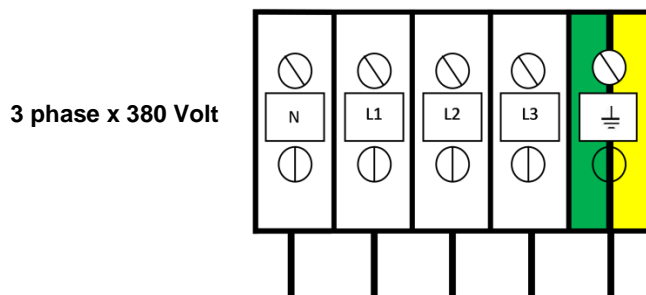

3 phase x 380 Volt



Classic PH/PHX-25

Follow the recommended procedure in the indicated order to install the Proportioner:

1. Insert the main power cable by passing it through the strain relief at the bottom of the Electrical Console and connect as shown in the above diagram.
2. Fill the Hydraulic Reservoir with 20 gallons (76 Liters) of approved hydraulic fluid. See page 52 for specifications.

NOTE! Do not fill the tank to maximum capacity; use the Visual Level Indicator on the tank to make sure the amount of hydraulic fluid is not more than 20 gallons (76 liters) or 80% of the tank max capacity.

3. Check the level of the hydraulic fluid in the Hydraulic Pump Case:
Disconnect the Hydraulic Hose from the 90° fitting and remove the Fitting from Hydraulic Case. Add fluid as required to the top of threaded hole. Reattach Fitting and Hydraulic Hose.

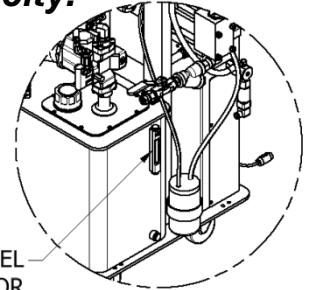

HYDRAULIC FILL/LEVEL INDICATOR

ENSURE THAT THE EMERGENCY STOP IS NOT ENGAGED

4. **Three-phase Proportioner Only:** Check the Electric Motor to ensure rotation is **clockwise** when viewing the end of the Electric Motor. A counter clockwise rotation indicates two of the incoming power leads need to be reversed.

CAUTION! Ensure Main Power Switch is OFF and incoming power is locked OFF before reversing power leads.

Recheck rotation before proceeding with Installation.

5. Fill the Lube Reservoir with PMC Pump Lube or suitable diluents. It is not necessary to prime the system.

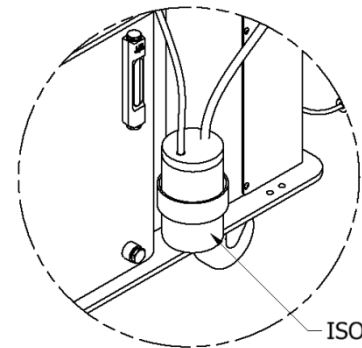

ISO LUBE RESERVOIR

Heated Hose Installation

CAUTION! The material delivery Heated Hoses are color coded Red and Blue allowing the user to recognize them. The Red corresponds to the Isocyanate (Iso, A) and the Blue to the Polyol (Poly, R). To avoid connection errors the Coupling Connections of the Iso (A) and Poly (R) Heated Hoses are also different sizes, which makes it difficult to swap connections.

NOTE! The material delivery Heated Hoses are capped at the ends to prevent absorbing moisture. Do not remove caps until the Heated Hoses are going to be installed on the Proportioner.



Classic PH/PHX-25

1. Lay out all the Heated Hose assemblies end to end aligning the Iso “A” (red) and Poly “R” (blue) and connect the respective Coupling Connections using the appropriate sized open-end wrench after ensuring Heated Hose assemblies lay flat.

CAUTION! Take care to not cross-thread or over-tighten the Coupling Connections. Thread seal tape or compound is not required for this tapered seat Coupling Connections.

2. Connect the material Heated Hoses to the outlets of the respective Heaters i.e. Iso (A) Heated Hose to the Iso (A) Heater and the Poly (R) Heated Hose to the Poly (R) Heater ensuring Heated Hose assemblies lay flat.
3. Connect Air Hose Coupling Connections.

4. Connect the Heated Hose power wires to the “Fast-Lock” Connector (Part # KT-00029A) coming from the Hose Heat Transformer as follows:

- a. Loosen the Socket Head Set Screw to allow insertion of the Heated Hose electrical wire Terminal.
- b. Insert the Terminal into the “Fast-Lock” Connector Body.
- c. Securely tighten the Socket Head Set Screw.
- d. Install electrical tape around Connector Body.

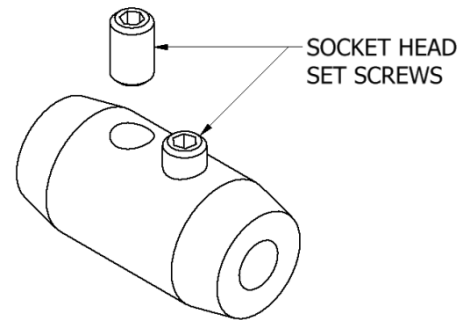

NOTE! A good practice is to add some dielectric grease (Permatex 67VR or equivalent) to the outside of the Terminal prior to insertion.

Repeat the above steps to connect the “Fast-Lock” Connectors that you will find on all Heated Hose power wire.

CAUTION! Ensure the proper mechanical and electrical connections of the Heated Hoses are made to avoid possible material leakage and Hose heat problems.

5. It is recommended the TSU be installed between the last section of Heated Hose and the Gun Whip. Carefully straighten the sensing wire, inserting it in the Iso (A) Heated Hose and tighten fluid fittings with appropriate sized open-end wrenches.

CAUTION! To protect the TSU sensor, you must pay special attention not to kink or excessively bend the Heated Hoses. Do not coil the Heated Hoses with a diameter of less than 4 feet (1.22 Meters).



Classic PH/PHX-25

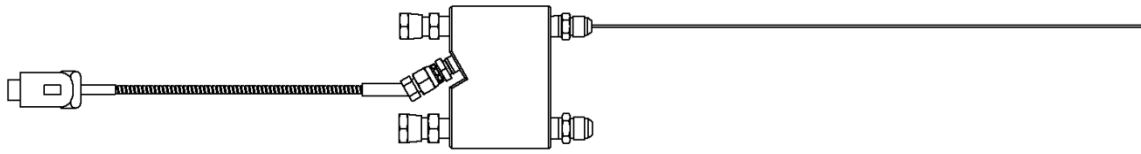

Temperature Sensing Unit
(TSU) Part # EL-51A
Replacement Sensor Part # EL-51A-2

CAUTION! Connecting the TSU between the first and second section of Heated Hose results in the TSU sensing the material temperature exiting the Heater and not the inside of the Heated Hose near the Spray Gun.



Classic PH/PHX-25

TRANSFORMER SETTINGS

The Hose Heat Transformer offers the ability of connecting to different output voltages depending on the total length of the Heated Hose in use, maximizing the heating ability of the Heated Hose. The factory setting is 18 volts for use with 60 feet (18 Meters) of Heated Hose. Before starting the Proportioner, ensure the setting matches the Heated Hose length installed. If Heated Hose sections are added or removed, the Tap setting must be changed to a setting which will limit the maximum amperage in the Heated Hose to 52 amps. The suggested tap settings are tabled below:

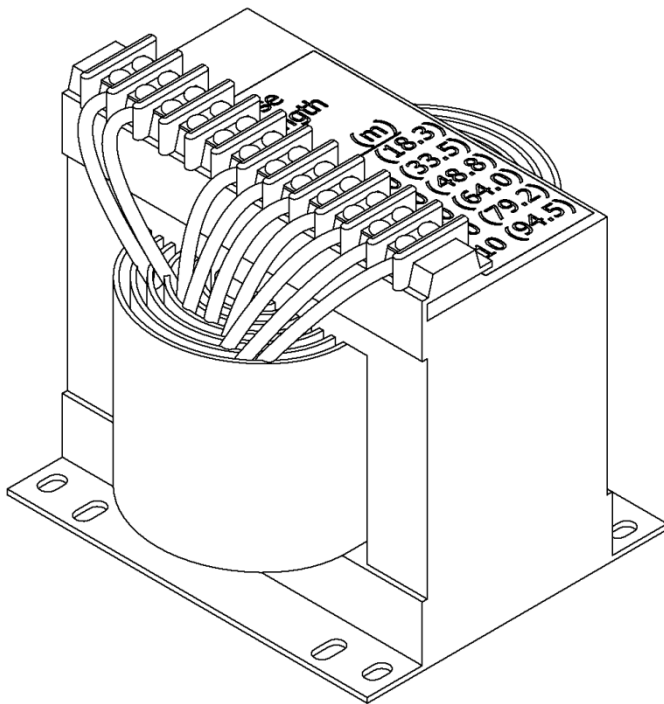

Tap	Feet	Meters
90v	310	94.5
75v	260	79.5
60v	210	64.0
45v	160	48.8
30v	110	33.5
18v	60	18.3

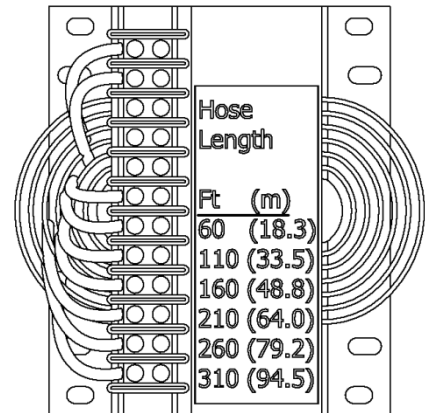

- Ensure the Manual Valves are CLOSED and connect the Coupling Block to the Heated Gun Whip.

CAUTION! Excessive force closing or opening the Manual Valves may result in damage to the Manual Valves and/or Coupling Block.



Classic PH/PHX-25

7. Connect the Transfer Pump/Heated Hose Assemblies air supply and air dryer systems as required. Review the Installation Instructions for each to ensure proper set-up and operation.
8. Install the Material Transfer Pumps as follows:

WARNING! If Transfer Pumps have been previously used, pay special attention to connect each Pump to “its” specific material. Inadvertently changing the Transfer Pumps will cause a chemical reaction rendering them useless.

NOTE! Placing tape of the same color as of the Material Delivery Hoses (red for the Iso (A), blue for the Poly (R)) on each Transfer Pump would be a good method for minimizing errors in connection.

- a. Make sure that the Inlet Valves on the Proportioner are closed.
- b. Connect one end of the Polyol (R) Material Delivery Hose ($\frac{3}{4}$ " thread) to the Proportioner Polyol (R) Inlet Valve and the other end to the Polyol (R) Transfer Pump.
- c. Connect one end of the Iso (A) Material Delivery Hose ($\frac{1}{2}$ " thread) to the Proportioner Iso (A) Inlet Valve and the other end to the Iso Transfer Pump.
- d. Connect the air hose to the Transfer Pumps after ensuring each Transfer Pump Shut-Off Valve is CLOSED.

NOTE! To avoid errors in connection, the Coupling connections of the Iso (A) and Poly (R) Material Delivery Hoses are different sizes, making it difficult to swap connections.

- e. Ground the Transfer Pump as recommend by the material supplier. The movement of product inside the Hoses can cause static electricity and produce electrical discharges.

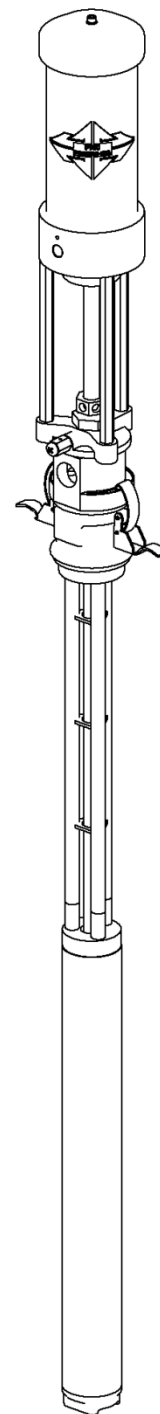



Classic PH/PHX-25

PROPORTIONER PURGING

WARNING! Use suitable Personal Protection Equipment (PPE) and follow the recommendations in the Safety Information provided by product suppliers when installing or working with the unit.

NOTE! Before using the Proportioner it is necessary to purge the entire system, including Heated Hoses of mineral oil and air left over from Quality Control testing. The following procedure is also followed to purge air entrapped by running out of material in the supply Drum/Reservoirs resulting in a significant material pressure imbalance as indicated by the Pressure Gauges and sprayed material.

1. Ensure the following before proceeding:
 - a. Air supply to Transfer Pumps is 90 - 110 psi (6-8 Bar).
 - b. Proportioner Inlet Valves are CLOSED.
 - c. All connections are tight.
 - d. Material should be stored to the material suppliers' recommended temperatures.
2. Slowly OPEN the Poly (R) Transfer Pump Air Shut-Off Valve allowing Pump to cycle slowly as it fills the Material Delivery Hose to the Proportioner. Check for leaks.
3. OPEN Poly (R) Coupling Block Manual Valve over a waste container.
4. Slowly OPEN Proportioner Poly (R) Inlet Valve allowing the Transfer Pump to move material through the system. When all air spitting stops and all traces of mineral oil have disappeared, CLOSE Poly (R) Coupling Block Manual Valve. Clean Coupling Block.
5. Repeat steps 2 to 4 for Iso (A) side.

CAUTION! Properly dispose of all waste chemicals in accordance with all applicable local, state and federal codes.

DO NOT turn on the Count Down Counter.

6. Turn Hydraulic Pressure Control (N, page 12) full COUNTERCLOCKWISE.
7. Turn ON Main Power (Q, page 13). Green pilot will light.
8. Turn ON Control Power (S, page 13). Switch will light.
9. Turn ON Motor Power (W, page 14). Switch will light.
10. Set Pump Switch (X, page 13) to NORMAL. Turn Hydraulic Pressure Control CLOCKWISE (N, page 12) increasing **material pressure** to 400 psi.(27 Bar) Both Material Pressure Gauges (H, K, page 12) should read the same.
11. Check all connections for leaks.
12. Bundle all Heated Hose Connections ensuring that there are NO kinks in the TSU Cable or Air Hose. Wrap with Electrical Tape to securely hold all components in place and minimize places for bundle to snag onto job site protrusions.



Classic PH/PHX-25

PRESSURE BALANCE CONTROL

The PH Series Proportioner has been designed with a pressure balance control system. This system will give the operator of this machine the ability to control a pressure imbalance within certain predetermined parameters.

The system consists of:

- Selector Switch
- Fault Light
- On Light
- Control Unit
- Pressure Transducers
- Relay

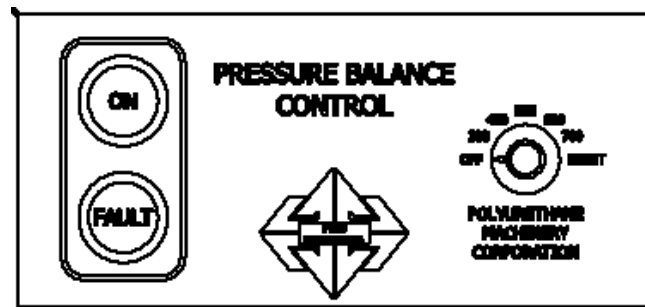

OPERATION

Position the selector switch on one of the three options:

- **Pressure differential number** – these consist of 300, 400, 500, 600, and 700 PSI. Selecting any of these numbers with the switch will activate the green ON light. While the pressure differential numbers are selected, the control box will continually monitor pressure on both sides of the Proportioner. In the event that the pressure differential between both sides of the Proportioner is equal to or larger than the selected number, a fault is given (the red fault light is turned on and the active green light is turned off) and shuts down.
- **Off** – if the selector switch is placed in this position, the Proportioner will operate as though there is NO PRESSURE BALANCE CONTROL SYSTEM (neither the red fault light nor the active green light will be lit). The over pressure system will remain active for the machine and personnel protection.
- **Reset** – in the event of a pressure imbalance, resolve the Proportioner imbalance, position the selector switch on reset to clear the fault light and restore power to the Proportioner. After the fault has been cleared, position the switch in either a Pressure Differential number or in the Off Position to continue operations.









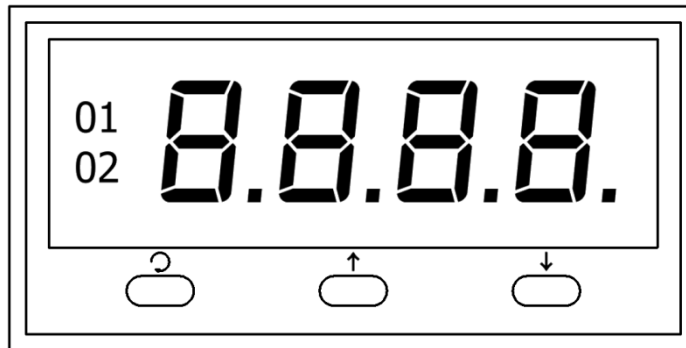

Classic PH/PHX-25

DIGITAL TEMPERATURE CONTROLLER

The PH Series has three Digital Temperature Controllers to manage the temperatures for the Primary Heaters (Iso (A), Poly (R)) and the Heated Hose. The Hose Heater Controller is programmed different from the Iso (A) and Poly (R) Controllers and therefore not interchangeable with them.

WARNING! Do not turn the Temperature Controllers ON until the Proportioner Purging procedure is complete and the Primary Heaters and Heated Hoses are filled with material.



1. Ensure Main Power (Q, page 13) is ON, Control Power (S, page 13) is ON and **01** Display light is lit.
2. Press and release  button. The display will read **SP1**.
3. Press and release  **or**  button to display the **current material temperature set-point**.
4. Press and hold the  **or**  to **increase** or **decrease** the material temperature set-point to the desired value as determined by the material supplier or application conditions.
5. Press and release  **and**  together to return to the **actual material temperature** in the Primary Heater/Hose Heater.

WARNING! The Controllers are factory programmed and are not field re-programmable. If a problem is encountered, contact your PMC Distributor. Do not attempt to change any of the programmed parameters. Do not substitute a Controller from an alternate supplier as its use may result in equipment damage and/or bodily injury.

NOTE! The Temperature Controller normally displays the actual material temperature. When lit, the “01” display in the upper left indicates power is sent to the designated heating system. The “01” display goes out when the material temperature has reached its set-point. The “01” display will continue to cycle on and off indicating the Controller is maintaining the material temperature set-point.



Classic PH/PHX-25

START-UP

NOTE! Follow the recommended procedures in the order shown.

CAUTION! The Start-up procedures assume that all of steps in Proportioner purging have been performed and no problems found.

1. Check the condition of the PMC pump lube in the Iso (A) Lube Reservoir (page 16). Replace the PMC pump lube if you see significant changes in the color or signs of solidification. Ensure inside of Reservoir is wiped clean.
2. Check the hydraulic fluid level and service as required.
3. Make sure the materials have been stored at the manufacturer's recommended temperature. Ask your material supplier for information (Material Data Sheet) on the minimum storage temperature.
4. Connect air supply to the two Transfer Pumps and ensure Air Valves are in the full OPEN position. OPEN both Proportioner Material Inlet Ball Valves.

CAUTION! Remove all Heated Hose sections from coiled storage and lay flat to eliminate heat build-up and possible Heated Hose failure.

5. Turn ON Main Power (Q page 13).
6. Turn ON Control Power (S, page 13).
7. Turn ON Hose Heater (T, page 13) and confirm material set-point temperature as recommended by the material supplier or application conditions.

CAUTION! To avoid excessive pressure in the Proportioner, wait for the Hose Heater to reach its set-point temperature before continuing.

8. Turn ON each Primary Heater and confirm material set-point temperature as required by the material supplier or application conditions has been reached.
9. Turn ON Motor Power (W, page 14).
10. Set Pump Switch (X, page 13) to NORMAL. One of the Directional Indicator Lights (Y, page 14) will light indicating Metering Pump direction and the Metering Pump Shafts will begin to move.

NOTE!

- a. The Material Pressure Gauges (H, K, page 12) should be approximately equal and remain constant throughout the Metering Pump cycle. If not, refer to Trouble Shooting section.
 - b. Directional Indicator Lights must indicate Metering Pump direction when Pump Switch is in the NORMAL position. If not, refer to Trouble Shooting section.
11. Using the Hydraulic Pressure Control, adjust to the required stall pressure^① and check each Material Pressure Gauge.

① Stall pressure: When materials are at recommend application temperature and Metering Pumps are pressurized but not moving. This pressure is normally 100 – 200 psi (7-14 Bar) greater than the developed spray pressure as recommended by the material supplier.



Classic PH/PHX-25

12. COUNT DOWN COUNTER

If this function is not needed leave it in the off position.

To set the Auto Shut Down Counter:

- Turn the switch to the on position, the green light will illuminate.
- Insert the number of cycles desired to disable the pump circuit by pushing in on the white triangles to set the cycle count. Push in on the red button until the data is replicated on the top row, the top row will count down. Figure B

120 pumps 16 cycles = 1 gallon/3.79 Liters
--

80 pumps 24 cycles = 1 gallon/3.79Liters
--

- When the counter counts down to zero the machine will stop and the pump directional light will be off, push in on the red button to reset. Figure C

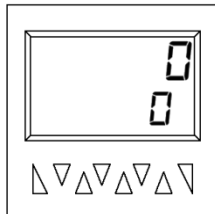

FIGURE A

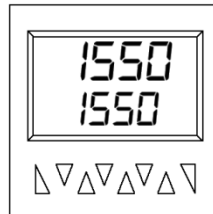

FIGURE B

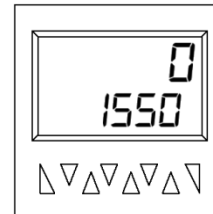

FIGURE C

- Proceed with Installation and Start-up of the Spray Gun as per the Gun manual.



Classic PH/PHX-25

SHUT-DOWN

Follow the recommended procedure in the indicated order for Proportioner temporary shut-down such as **lunch breaks**.

1. Set Pump Switch (X, page 13) to OFF position.
2. Turn each Heater OFF. Hose Heater should remain ON. Never leave Proportioner ON if unattended.
3. CLOSE Spray Gun Manual Valves.

CAUTION! Excessive force opening or closing the Manual Valves may result in damage to the Manual Valves and/or Coupling Block.

Follow the recommended procedure in the indicated order for Proportioner shut-down when work is **stopped for the day**.

1. Set the Pump Switch (X, page 13) to RETRACT.
2. Spray off the application surface until Material Pressure Gauges (H, K, page 12) readings begin to fall.

CAUTION! To avoid possible Proportioning Pump Seal seepage and moisture vapor drive into the Heated Hoses, the system pressure should not be reduced to zero. It is recommended to lower the system pressure to a minimum of 400 psi (27 Bar).

3. CLOSE the Spray Gun Coupling Block Manual Valves.

CAUTION! Excessive force opening or closing the Manual Valves may result in damage to the Manual Valves and/or Coupling Block.

4. Turn OFF Motor Power (W, page 14).
5. Turn OFF the A and R Heaters and Hose Heater (T, page 13).
6. Turn OFF the Auto Shut down switch.
7. Turn OFF the Control Power (S, page 13).
8. Turn OFF the Main Power (Q, page 13).
9. Disconnect the air supply to the two Transfer Pumps and CLOSE the Proportioner Material Inlet Valves.



Classic PH/PHX-25

TROUBLESHOOTING

The PH Series Proportioner has been designed and built to withstand severe working conditions with a high degree of reliability, provided that it is used in a suitable application by a properly trained operator. This chapter contains information on possible faults that may interrupt the operation of the PH Series Proportioner. The information provided will serve as a guideline to detect and resolve problems. In any case, feel free to contact your authorized PMC Distributor, where a qualified technician will advise you.

CAUTION! All repairs performed by unqualified personnel or the use of spares other than originals may cause damage to the unit and put the operator at risk.



To prevent possible injury caused by incorrect handling of the raw materials and solvents used in the process, carefully read the safety data sheet provided by your supplier.

Deal with the waste caused according to current regulations.



To avoid damage caused by the impact of pressurized fluids, do not open any connection or perform maintenance work on components subject to pressure until the pressure has been completely eliminated.



Use suitable protection when operating, maintaining or being present in the area where the equipment is functioning. This includes, but is not limited to, the use of protective goggles, gloves, shoes and safety clothing and breathing equipment.



The equipment includes components that reach high temperatures and can cause burns. Hot parts of the equipment must not be handled or touched until they have cooled completely.



To prevent serious injury through crushing or amputation, do not work with the equipment without the safety guards installed on the moving parts. Make sure that all the safety guards are correctly reinstalled at the end of the repair or maintenance work of the equipment.



Classic PH/PHX-25

TROUBLESHOOTING

HEATERS

WARNING! Before troubleshooting make sure the Main Power Switch is OFF and incoming power is locked OFF. NEVER access the inside of the Control Panel with the Proportioner power supply ON. The Heaters are components that reach high temperatures; you must wait until they cool before handling.

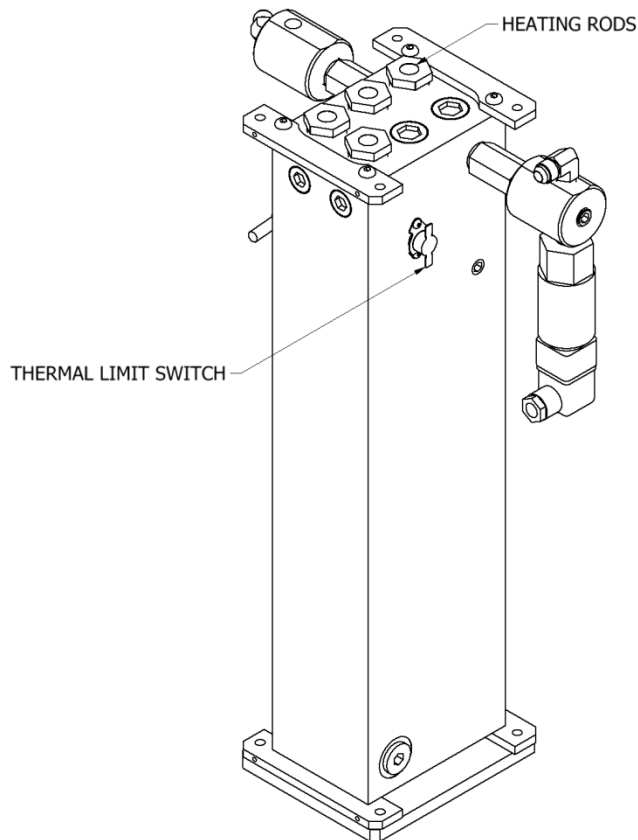

NOTE ! The Thermal Limit Switch is a safety switch in contact with the Heater body. If the surface temperature exceeds 220° F (109° C), the Limit Switch will shut off the Heater power. The Limit Switch will not re-set until the temperature in the Heater is below 190° F (88° C). **The system is designed that in case of an over temperature a contactor will open disabling power to both Heaters and the Hose.**

Follow the recommended procedure in the indicated order to solve the problem and avoid unnecessary repairs. Make sure all Switches are in the correct position and Indicator Lights ON before determining the existence of a fault.



Classic PH/PHX-25

PROBLEM

Primary heater does not heat and the display on the controller shows ambient temperature.

SOLUTIONS

1. Check that the light on the on/off switch is lit when the heater is turned on, if not replace the switch.

If the light is on move to the next step.

2. Check the heater breaker in the main console, reset the breaker, if it continues to trip, wrap an Amp Clamp around one of the wires coming off the breaker. If the Amperage reading does not exceed the rating of the breaker, the breaker needs to be replaced. If the breaker draws more than its rating the most likely cause is that one or more of the fire rods is shorted. Remove the heater cover, disconnect the wires and check each rod for resistance. Refer to page 30.

If the breaker is not tripped move on to the next step.

3. Open the console top and locate the solid state relays for the heaters, looking over the console top from the front of the machine. There are two relays to the left bottom of the console, the one to the far left is for the "A" heater and the one to the right is for the "R" heater. With the heater on look to see if a LED light is lit on the relay.

If there is no LED light on the solid state relay move to the next step.

4. With a DC volt meter read across position A1 and A2 on the solid state relay (smaller wires) if you have a reading of 4-6 volts DC and the AC reading across L1 and L2 (Heavy wires) reads 208-230 volts AC replace the solid state relay. With 24 volt DC at A1 and A2 the proper reading should be 1 volt AC across L1 and L2. If the AC reading across L1 and L2 is .025 volts check the over temperature switches in the heaters. A defective over temperature switch will open a contactor disabling both Heaters and the Hose.

If there is no DC voltage to the relay move to the next step.

5. Using a DC volt meter measure across position 5 and 6 on the back of the heater controller this is the output of the controller and sends power to the solid state relay, your reading will be 4-6 volts DC. If there is no reading check to make sure that the set temperature on the controller is above the actual temperature reading on the controller. Before replacing the controller read across position 1 and 2 to make sure that the controller is powered up, your reading will be 208 to 230 volts AC. If no voltage is present check for loose wires or a malfunction of the heater circuit breaker.



Classic PH/PHX-25

PROBLEM

Primary heater does not heat and the display on the controller shows a flashing error message SbEr.

SOLUTIONS

1. Check position 9 and 10 on the heater controller for loose wires.

If the wires are tight move to the next step.

2. Remove the heater cover and check that the thermocouple wires are secure to the harness going up to the controller.

If there are no loose connections replace the thermocouple.

PROBLEM

Primary heater controller shows excessive temperature and the circuit has turned off.

CAUTION! The heater must be allowed to cool down before continuing.

SOLUTIONS

1. Set the controller set point at least 20°F (7° C) lower than the temperature shown on the controller. Briefly turn on the heater and look for the LED light on the solid state relay to be on.

If the light is on replace the controller.

If the light is off replace the solid state relay.

PROBLEM

Primary Heater Temperature drops excessively while spraying.

POSSIBLE CAUSE

1. Temperature of the chemical in the containers is too cold.
2. Exceeding the flow rate specification of the machine.

CAUTION! Disconnect power to the machine before proceeding.

3. One or more of the fire rods in the heater have malfunctioned. Remove the heater cover and disconnect the wires to measure the resistance across each rod. Installing a smaller mixing chamber in the gun may allow you to spray until a new rod(s) is installed.

CAUTION! If the rod that is used in conjunction with the thermocouple is defective do not operate the heater until the rod is replaced.

INDIVIDUAL OHMS MEASUREMENT	
1000 WATT	41 OHMS
1250 WATT	37 OHMS
1500 WATT	31 OHMS



Classic PH/PHX-25

HYDRAULIC DRIVE SYSTEM

Follow the recommended procedure in the indicated order to solve the problem and avoid unnecessary repairs. Make sure all Switches are in the correct position and Indicator Lights ON before determining the existence of a fault.

WARNING! Before correcting any kind of defect, make sure the Main Power Switch is OFF and the incoming power is locked OFF. NEVER access the inside of the Control Panel with the Proportioner power supply ON. The Hydraulic Unit is a component that works under pressure. Do not open any connection or carry out maintenance on components subject to pressure until all pressure has been bled to zero.

CAUTION! Do not attempt to reset the Motor Contactor more than twice. Failure of the Motor Contactor safety mechanism will occur and the Contactor will become inoperable and/or the Motor damaged. The cause of the problem must be determined and corrected.

PROBLEM

Motor does not run and Hydraulic Pump does not develop pressure.

SOLUTIONS

1. Motor Contactor Safety

The Electric Motor is protected from excessive current by an Overload Safety Switch. After allowing the Motor to cool, open the Control Panel and reset Motor Contactor Safety.

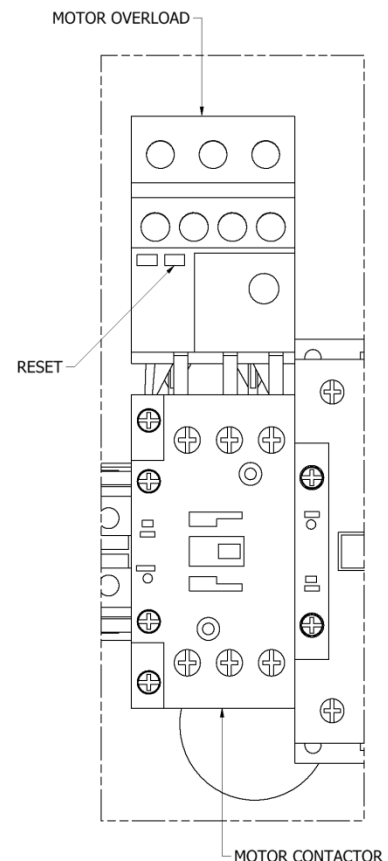



Classic PH/PHX-25

PROBLEM

Motor runs but Hydraulic Pump does not develop pressure

SOLUTIONS

NOTE! Hydraulic pressure is not generated if the Motor Power Switch (W, page 14) is OFF or the Pump Switch (X, page 13) is in the OFF position.

With the Pump Switch in the NORMAL position, the failure of the Hydraulic Pump to develop pressure is loss of pump suction (prime). To ensure positive prime, check the following:

1. Motor rotation (page 16).
2. Hydraulic Reservoir is filled to the correct level (page 16).
3. Hydraulic Pump Case is filled with the proper hydraulic fluid (page 52).
4. Loose Inlet Plumbing: Check that all inlet plumbing to the Hydraulic Pump is tight ensure there is no air leakage into the hydraulic system.

PROBLEM

Low or zero hydraulic pressure with unusual Hydraulic Pump noises.

SOLUTION

1. The use of an incorrect hydraulic fluid can result in unusual noises from the pump, excessive wear and moisture absorption. Ensure the hydraulic oil used is from the list on page 52. In addition to the above, continuous excessive hydraulic oil temperature as well as failure to change the hydraulic oil on a yearly basis will cause the oil to fail and result in excessive Hydraulic Pump wear and unusual noises.
2. Loose Inlet Plumbing: Check that all inlet plumbing to Hydraulic Pump is tight ensuring no air leakage into the hydraulic system.

NOTE! Hydraulic Pressure will not be developed in the off position if the pump switch is in the off position or if there is a malfunction in the pump circuit.



Classic PH/PHX-25

METERING PUMP LINE

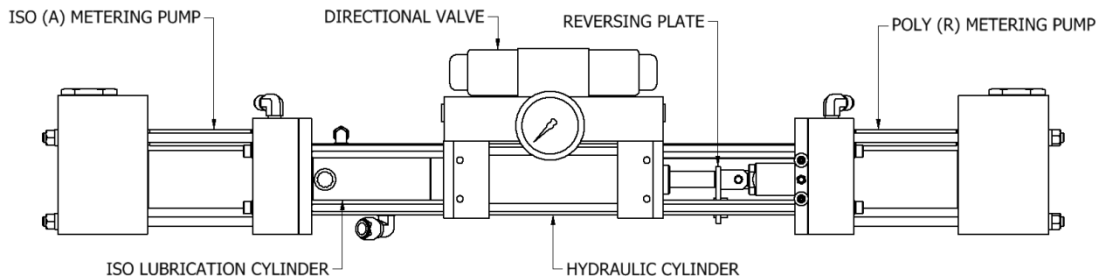

Follow the recommended procedures in the indicated order to solve the problem and avoid unnecessary repairs. Make sure all Switches are in the correct position and Indicator Lights ON before determining the existence of a fault.

PROBLEM

Metering pumps do not change direction and the pressures on both of the chemical gauges are lower than normal.

SOLUTIONS

1. The Metering Pump Line has a Reversing Plate which actuates two Proximity Switches, one at each end of the stroke. The Prox Switches in turn actuates the appropriate Directional Valve Solenoid.

Failure to make contact with either PROX Switch may be caused by:

- ✓ Deformation of the Reversing Plate.
- ✓ Foreign material preventing the Reversing Plate from contacting the Prox Switches. **If this is not the problem go to the next step**

2. Passing of the Reversing Plate beyond the Prox Switch may be caused by:

- ✓ Failure of the Prox Switch and related components on the side of the over-run.
- ✓ Failure of a component of the Directional Valve.
- ✓ Mounting Plate and/or Prox Switch is out of adjustment.

IF THE DIRECTIONAL INDICATOR LIGHT IS ON CHECK THE REVERSING VALVE COIL ON THE SIDE THAT THE LIGHT IS ON. IF YOU HAVE 24 VOLTS DC AT THE PLUG CHECK THE OHM'S RESISTANCE OF THE COIL, IT SHOULD READ APPROXIMATELY 19 OHM's, IF NOT REPLACE THE COIL OR REVERSING VALVE.



Classic PH/PHX-25

IF THE DIRECTIONAL LIGHT IS **OFF** PROCEED BELOW

BEFORE TROUBLESHOOTING, THE REVERSING SWITCH PLATE MUST BE MOVED AWAY FROM THE SWITCH.

- Bleed the down the chemical pressures.
- Ensure Pump Switch (X, page 13) is **OFF**.
- Turn on the motor (W, page 14).
- Go to the Directional Valve and locate the Actuation Coils. Located in the middle of each coil is small round tab that can be pushed in to manually shift the spool to move the pumps. If the Reversing plate is all the way to the left push in on the right side coil. If it's all the way to the right side, push in on the left side coil.

WARNING! THE MOTOR MUST BE OFF AND THE PUMP SWITCH IN THE NORMAL POSITION.

Take a small screw driver or a thin piece of metal and move it across the front of each Prox switch. A red light on the back of the switch should illuminate. If not replace the switch that does not light.

If the Prox switches light up turn off all power and check for continuity on both over pressure switches, pin 1 and 2. If the pressure switches are good go to the two solid state relays inside the console and interchange them, they can be pulled from their housing. Power up the unit with the pump switch in the normal position and the motor **OFF**. If the directional light comes on replace the defective solid state relay. If not replace the Latching relay.

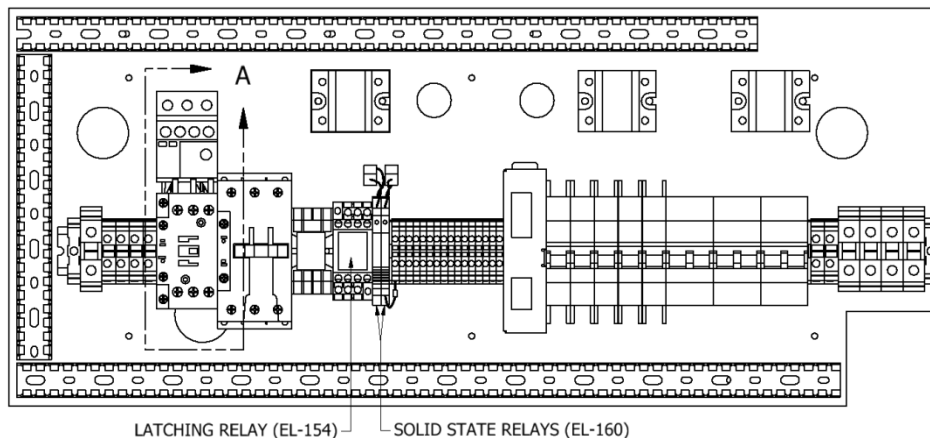



Classic PH/PHX-25

3. Safety Pressure Switch

Each Metering Pump has a Safety Pressure Switch (I, L, page 12) set to 2,200 psi (152 Bar) for #120 pumps, 3,200 psi (221 Bar) for #80 pumps. When the material system reaches this pressure, the Safety Pressure Switch will remove power from the Directional Valve and Direction Indicator Lights (Y, page 14). Lack of Direction Indicator Lights along with high pressure indicated on one or both of the material Pressure Gauges (H, K) is an indication of a over-pressure condition. The Safety Pressure Switches are a momentary design; when the pressure bleeds off the Metering Pump Line will resume normal operation. However, the cause of the over-pressure should be determined and corrected. The three most common causes are:

- a. Cavitation of the Metering Pump on the **low** pressure side causing high pressure on the opposite side.
- b. A restriction in the Spray Gun on the **high** pressure side.
- c. Hydraulic pressure set too high for Spray Gun Mixing Chamber.

4. Pressure/Material Imbalance

In summary troubleshooting this problem requires the applicator to:

- a. Know what the NORMAL spray pressures are for the application in progress.
- b. Determine what material is NOT exiting the Mixing Chamber.
- c. Read the Pressure Gauge on the problem side and interpret the reading.

MATERIAL CONDITION	"A" GAUGE	"R" GAUGE
NORMAL		
LACK OF ISO (A)		
LACK OF POLY (R)		
RESTRICTION OF ISO (A)		
RESTRICTION OF POLY (R)		



Classic PH/PHX-25

5. Cavitation

Cavitation occurs when the Metering Pump (B, or C, page 12) requires a larger volume of material than the supply system (Transfer Pump) can furnish. This creates a "void" of material in the Metering Pump. The most common causes of cavitation are:

- a. Material temperature **too low** causing increased material viscosity resulting in the inability of the Transfer Pump to maintain sufficient supply to the Metering Pump. This is most common with today's blown systems. Ensure the **material** temperature in the drums is no lower than the material suppliers' recommendation.
- b. Failure to vent the material drum while drawing material out with the Transfer Pump causes a vacuum and cavitation in the Transfer Pump. Ensure the drum is vented to the atmosphere or a Desiccant Air Dryer Kit is installed as recommended by the material supplier.
- c. Air volume is insufficient for the Transfer Pump or if the Transfer Pump Air Valve is partially closed, this will limit the ability of the Transfer Pump to operate at its maximum capability.
- d. Inlet Material Screen (O) obstructed (See **MAINTENANCE** section).
- e. Metering Pump Inlet Ball does not seat properly allowing material to flow back into the Material Delivery Hose when the Metering Pump is on the "Discharge" stroke. This causes the volume of material on that Metering Pump to be less on the discharge stroke resulting in intermittent off-ratio material and Pressure Gauge fluctuation.

6. Pressure Loss: Discharge/Inlet Ball

Simultaneous observation of the material Pressure Gauge (H, K, page 12) and Directional Indicator Light (Y page 14) is necessary to determine which direction the Metering Pump fails to maintain pressure. Refer to the chart to determine the problem:

	Left Directional Indicator Light ON	Right Directional Indicator Light ON
Iso Pressure Gauge FALLS	Iso Inlet Ball does not seat properly	Iso Discharge Ball does not seat properly
Poly Pressure Gauge FALLS	Poly Discharge Ball does not seat properly	Poly Inlet Ball does not seat properly

In most cases the cause of a leaking Inlet/Discharge Ball is foreign material preventing the Ball from seating properly. If the above steps do not resolve the problem, replace the appropriate Ball, Ball Seat, Ball Seat Gasket and the O-ring on the cage.

For service see [MAINTENANCE/Metering Pump Line/page 44](#).



Classic PH/PHX-25

HOSE HEATING

WARNING! Before correcting any kind of defect, make sure the Main Power Switch is OFF and incoming power is locked OFF. NEVER access the inside of the Control Panel with the Proportioner power supply ON. The Heated Hoses are components which reach high temperatures. Wait until they have cooled before handling.

Follow the recommended procedure in the indicated order to solve the problem and avoid unnecessary repairs. Make sure all Switches are in the correct position and Indicator Lights ON before determining the existence of a fault.

CAUTION! All electrical testing must be done by a qualified electrician.

PROBLEM

A-Heated hose does not heat and the display on the controller shows ambient temperature.

SOLUTIONS

1. Check that the light on the on/off switch is lit when the heater is turned on, if not replace the switch.

If the light is on move on to the next step.

2. Check the Hose Heat Breaker in the main console reset the breaker. If it continues to trip wrap an Amp Clamp around one of the wires coming off the breaker. If it does not draw more than the rated value of the breaker, the breaker needs to be replaced.

If the breaker is not tripped move on to the next step.

3. Check the circuit breaker mounted on the transformer, reset the breaker. If it continues to trip wrap an Amp Clamp around one of the wires from the transformer going to the heated hose. If it does not draw more than the rated value of the breaker, the breaker needs to be replaced.

If the AMP draw is less than the rated value move on to the next step.

4. Check that the tap setting on the transformer is set for the proper hose length.

If it is set correctly move to the next step.

5. Look at the two lights located on the front of the transformer. If the voltage light is lit and the AMP light is off the problem could be in the heated hoses. If the voltage light is on there is power to the primary side of the transformer. To check the secondary side of the transformer you must take an AC volt reading across the two leads coming out of the transformer that are connected to the "A" and "R" hose leads. If you are reading voltage (your voltage reading will vary depending on what tap setting is used) most likely the problem is in the heated hose. Either a connector has come loose or there is a broken wire.



Classic PH/PHX-25

6. Remove one of the wires coming out of the transformer that is connected to either the “A” or “R” side of the heated hose. Using an ohms meter perform a continuity reading across the two lead wires coming off the machine end of the heated hose. If there is no continuity through the hose check for loose or broken connection between each section of hose. If all the connections are secure and there are no visible broken wires it is possible that the element on the hose or the lead wire has broken at its connection. Each hose must be checked individually for continuity. Because the gun whip takes the most abuse it is most likely that the problem is in the hose whip up at the gun end.

If no voltage is coming out of the transformer to the heated hose move on to the next step.

7. Open the console top and locate the solid state relay for the hose circuit (see page 34), looking over the console top (front of machine) it is the relay to the right. With the hose turned on and there is a LED light lit on the relay, take a volt meter set on DC and measure across position A1 and A2 your reading should be 24 volts, then take an AC volts measurement across position L1 and L2 (heavy wires). With the relay functioning properly you should have a 1 volt reading, if the reading is 18 to 90 volts AC the relay has malfunctioned and needs to be replaced. If the AC Reading across L1 and L2 is .025 volts check the over temperature switches in the heaters. A defective over temperature switch will open a contactor disabling both Heaters and the Hose.

If there is no light on the solid state relay move to the next step.

8. Using a DC volt meter measure across position 5 and 6 on the back of the hose controller, this is the output of the controller and sends power to the solid state relay, your reading will be **4-6 volts DC**. If there is no voltage check to make sure that the set temperature of the controller is above ambient temperature. Before replacing the controller read across position 1 and 2 to make sure that the controller is powered up, your reading will be 208 to 230 volts AC.

PROBLEM

Hose does not heat and the display on the controller shows a flashing error message “SbEr.”

SOLUTIONS

1. Check position 9 and 10 on the heater controller for loose wires.

If the wires are tight move to the next step.

2. Remove the transformer cover and check that the thermocouple wires are secure to the harness going up to the controller. If there are no loose connections, disconnect the wire from the TSU and connect it directly to the thermocouple harness coming out of the hose transformer.

If the controller still shows the error code replace the hose thermocouple.



Classic PH/PHX-25

If the error code goes away and temperature is now shown on the display of the controller then all the TSU harnesses from the TSU to the transformer need to be checked for loose connectors or one or more of the harnesses are defective.

PROBLEM

Heated hose controller shows excessive temperature.

SOLUTIONS

1. Set the controller set point at least 20°F (7° C) lower than the temperature shown on the controller. Briefly turn on the Hose Heater Switch and look for the LED light on the solid state relay to be lit.

If the light is on, replace the controller.

If the light is off, replace the solid state relay.

PROBLEM

Hose will heat but does not come up to set temperature.

SOLUTIONS

1. Check the tap setting on the transformer to ensure that the correct position has been selected for the length of hose being used. Depending on the machines incoming voltage you may have to move the tap setting higher (up one).

CAUTION! Do not exceed the trip value of the transformer hose breaker.

WARNING! Before correcting any kind of defect, make sure the Main Power Switch is OFF and incoming power is locked OFF. NEVER access the inside of the Control Panel with the Proportioner power supply ON.

NOTE! IN THE EVENT AN EQUIPMENT PROBLEM CANNOT BE RESOLVED AFTER FOLLOWING THE DETAILED INSTRUCTIONS CONTAINED IN THIS MANUAL, PLEASE IMMEDIATELY CONTACT YOUR PMC AUTHORIZED DISTRIBUTOR AND THEY HAVE DIRECT CONTACT WITH THE PMC TECHNICAL SERVICE DEPARTMENT.

FOR ALL PARTS AND FIELD SERVICE CONTACT YOUR PMC AUTHORIZED DISTRIBUTOR.



Classic PH/PHX-25

PRESSURE BALANCE CONTROL

If the Pressure Balance Control box is not working properly, follow these steps to resolve the potential issue:

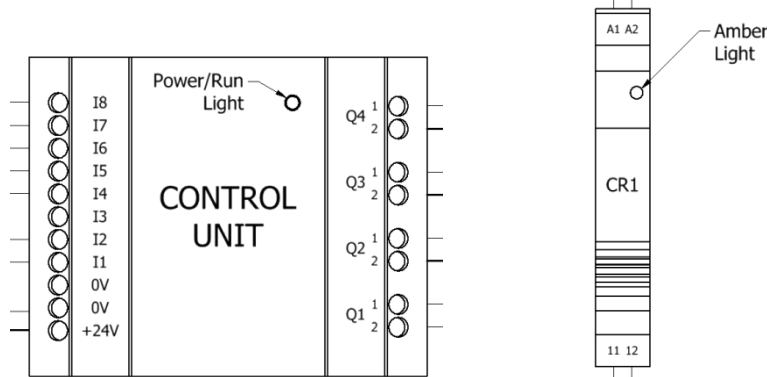

1. With the Main Power **ON**, check the Power/Run light on the Control Unit:
 - a. If **OFF**, the Control Unit is not getting power. Check for loose or poor wire connections. If the Power/Run light still does not turn on, contact your authorized PMC distributor.
 - b. If **SOLID**, the Control Unit has power but no program. Contact your authorized PMC distributor.
 - c. If **BLINKING**, the Control Unit has power and is programmed properly. Proceed to the next step.
2. With Main Power **ON**, turn the Rotary Switch to a Pressure Differential Number and check the Amber light on CR1:
 - a. If **OFF**, CR1 is not activating properly. Check for loose or poor wire connections between the Control Unit and CR1.
 - b. If **ON**, CR1 is activating, but the mechanical switch inside the relay may not be functioning properly. If the system has faulted (i.e. a pressure imbalance exists, the ON light turns off, and the FAULT light turns on), but the pumps do not shut off, check for continuity between contacts 11 and 12 on CR1. If there is continuity, contact your authorized PMC distributor. If there is discontinuity, proceed to the next step.
3. With Main Power **OFF**:
 - a. Check all remaining wires to ensure secure and proper connections.
 - b. Check for continuity across the ON light terminals and the FAULT light terminals. These light units are LEDs (light emitting diodes) which means that only one direction has continuity (similar to a check valve). When checking for continuity, make sure to use the correct terminals on the multimeter.
4. Contact your authorized PMC distributor for further assistance.



Classic PH/PHX-25

MAINTENANCE

To achieve maximum output from the PH Series Proportioner, a daily or regular maintenance schedule is required.



To prevent possible bodily harm caused by incorrect handling of the raw materials and solvents used in the process, carefully read the safety information provided by your supplier.



Deal with the waste created according to current regulations.

Disconnect the unit from the power supply before carrying out any operation inside the electrical console.

The electrical maintenance of the machine must only be performed by a qualified electrician.



To avoid damage caused by the impact of pressurized fluids, do not open any connection or perform maintenance work on components subject to pressure until the pressures have been completely eliminated.



Use suitable protection when operating, maintaining or remaining in the operating area of the unit. This includes, but is not limited to, the use of masks, protective goggles, gloves, shoes and safety clothing.



The unit includes components that reach temperature that are liable to cause burns. The hot parts of the unit must not be handled until they have cooled.



To prevent serious harm by crushing or loss of limbs, do not work with the unit without the safety duly installed on all moving parts. Make sure that all of the safety protections are correctly fitted after all repair or maintenance work.

CAUTION! All repairs performed by unqualified personnel or the use of parts other than supplied by PMC may cause damage to the unit and put the operator at risk.



Classic PH/PHX-25

INLET MATERIAL SCREENS

Inspection of the Inlet Material Screens on a daily basis is no longer necessary as long as the following conditions are met.

1. Material drums are stored within the recommended material storage temperature range and drums are not opened prior to installing the Proportioner Material Transfer Drum Pumps.
2. Desiccant air dryers are used to dry replacement air as material is removed from the drums to the Proportioner.
3. Consolidation of old material into a common drum for use is minimized especially the Iso (A).

If the above conditions are met, inspection of the Inlet Material Screens may be done on a **bi-weekly** basis.

NOTE! Inspect and clean Inlet Material Screens before Proportioner start-up. They should not be cleaned after the days operation as the Proportioner should be purged (see page 21) immediately after inspection and cleaning. This is to reduce the risk of moisture contamination and contamination through the reaction with any solvent used in the cleaning operation and cross-over at the Spray Gun due to air entrapment.

To check the Inlet Material Screens, proceed as follows:

CAUTION! Make sure the Main Power Switch is OFF and incoming power is locked OFF.

1. CLOSE the Poly (R) Proportioner Inlet Valve.
2. Place a suitable container under the Material Inlet Strainer to collect the residual material. Carefully loosen the Strainer Plug allowing the material to drain into the container.
3. Completely unscrew the Strainer Screw.
4. Remove the Seal, Spring and Screen and clean them with a suitable solvent. Dry the parts and ensure the Screen is not obstructed. Replace the Screen if more than 20% of the Screen surface is obstructed by residue.
5. Reinstall the Screen, Spring and Seal. Screw on the Strainer Screw and screw in Plug.
6. OPEN the Poly (R) Proportioner Inlet Valve, pressurize the Material Transfer Pump, check for leaks and wipe Y-strainer clean.
7. Repeat above for the Iso (A) side.
8. Proceed with Proportioner Purging operation (page 21).

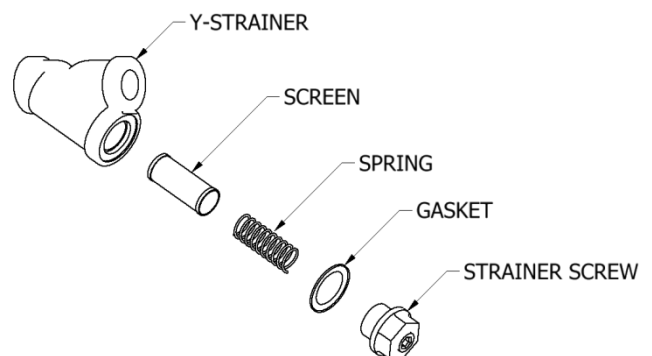



Classic PH/PHX-25

ISO LURICATION SYSTEM

Daily: Check the condition of the PMC Lube Oil in the Iso Lube Reservoir. Replace the PMC Lube Oil if you see significant changes in the color or signs of solidification. Ensure inside of Reservoir is wiped clean.

To replace the Lube Oil, proceed as follows:

1. Remove the Lube Reservoir from its support, unscrew the Lid and remove the Check Valve from the Suction Hose.
2. Empty the contaminated Lube Oil in a waste container and refit the Check Valve in the Suction Hose.

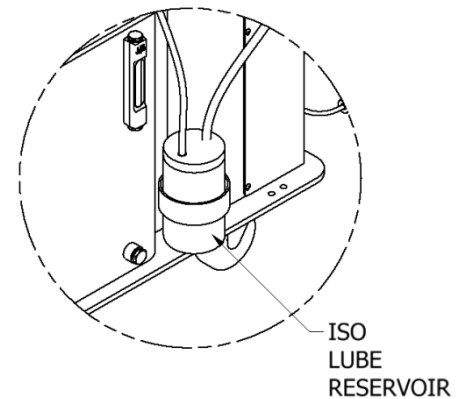

NOTE! Valve is directional.

3. Clean the Reservoir, refill with Lube Oil, and screw on the Lid and place the Reservoir in its support.

The system is auto-suction and does not need priming.

HYDRAULIC DRIVE SYSTEM

WARNING! Before performing any maintenance, make sure the Main Power Switch is OFF and incoming power is locked OFF. The Hydraulic Unit is a component that works under pressure. Do not open any connection or carry out maintenance on components subject to pressure until all press has been bled to zero.

The hydraulic unit should be serviced **yearly**:

1. Completely drain the Tank of hydraulic fluid.
2. Clean the Tank Top to prevent foreign material from falling into the Tank when the Lid is removed.
3. Unscrew the Suction Pipe from its connection with the Hydraulic Pump.
4. Remove the Lid and Suction Pipe from the Hydraulic Tank. Take care not to damage Tank Lid Gasket.
5. Inspect the bottom of the Tank for sediment and clean as required. Clean the Suction Pipe and its connections.
6. Insert the Suction Pipe into the Tank and replace the Lid. Again, take care not to damage Tank Lid Gasket. Connect the Suction Pipe securely to the Hydraulic Pump using thread sealant.
7. Fill the Tank with 20 gallons (76 Liters) of approved hydraulic fluid. See page 52 for recommendations.
8. Ensure the Hydraulic Pump Case is full of fluid (Installation, page 15) and proceed with the normal operation.



Classic PH/PHX-25

METERING PUMP LINE

WARNING! Before performing any maintenance, make sure the Main Power Switch is OFF and incoming power is locked OFF. Allow material temperature to cool below 80°F (27°C) and bleed all material pressure to zero.



Weekly: When the Proportioning Pumps are functioning properly it is not unusual for a small amount of Poly (R) material to appear on the Pump Shaft. This material should be wiped away so dirt does not accumulate on the Pump Shaft and the Pump Shaft Packings are not damaged.



Yearly or as required: Assuming the Iso (A) and Poly (R) is free from contaminants, the maintenance of the Iso Lube Reservoir (page 43) is performed, and the maintenance of the Poly (R) Pump Shaft (above) is followed, the Proportioning Pumps will perform for many maintenance free cycles. However, it is not unusual for those who use the PH Series Proportioner on a regular basis to rebuild the Proportioning Pumps on a yearly basis and service the Hydraulic Drive System at the same time, when the Proportioner is out of service.

Pump Base Service

To service Discharge/Inlet Ball

1. CLOSE appropriate Proportioner Inlet Material Supply Valve and remove Air Line from Transfer Pump.
2. Ensure all material pressure in the Proportioner system is zero and remove appropriate Retainer Nut.
3. For **Inlet Ball:**
 - a) Remove Inlet Ball with a Magnet (DO NOT USE ANY SHARP OBJECTS), clean Ball and Ball Seat, and inspect for foreign material and any flat spots on Ball.
 - b) Using supplied Ball Seat Tool (TL-02), check for proper Ball Seat/Ball Seat Gasket compression. Snug Seat up to ¼ turn **maximum (110 ft-lbs)**.

Pump Base Service

4. For **Discharge Ball:**
 - a) Perform step 1 & 2 from above.
 - b) Remove Cage and Spring.
 - c) Remove Discharge Ball with a Magnet, clean Ball and Ball Seat, and inspect for foreign material and any flat spots on Ball.
 - d) Using supplied Ball Seat Tool (TL-02), check for proper Ball Seat/Ball Seat Gasket compression. Snug Seat up to ¼ turn **maximum (30 ft-lbs)**.



Classic PH/PHX-25

Pump Seal Replacement

Refer to Parts Identification Drawing for reference.

NOTE!

- ✓ When the Iso (A) Proportioning Pump Cylinder is disassembled for service, all parts included in the Seal Kit (KT-05001-120 or KT-05001-080) should be replaced.
- ✓ When the Poly (R) Proportioning Pump Cylinder is disassembled for service, all parts included in the Seal Kit (KT-05002-120 or KT-05002-080) should be replaced.
- ✓ When assembling Proportioning Pump lubricate all Seals, Piston Rod and Pump Cylinder with #1 Lithium Grease to assist in assembly and minimize Seal damage during re-assembly.
- ✓ When the Pump Line End Block is disassembled for service, all O-rings included in the O-ring Kit (KT-05009) should be replaced.
- ✓ After reassembly of the Proportioning Pumps torque the Assembly Bolts to 30 ft/lbs.

CAUTION! Use wooden or plastic tools or a brass brush for cleaning. Do not use metal or abrasive tools that can scratch the contact surfaces.

METERING PUMP REMOVAL

If removing the Polyol side pump, skip steps 3 (three) and 4 (four).

1. Put machine in retract position.
2. Turn off main power and discharge all pressure gauges to 0 (zero).
3. Disconnect the bottom elbow on the Iso lube cylinder and drain all Iso lube.
4. Disconnect the top hose going to Iso lube cylinder then uninstall red plug.
5. Remove clevis pin.
6. Disconnect the hose on the pump flange.
7. Disconnect the Y-strainer from elbow.

Carefully remove the 4 bolts and washers while holding the pump in place.



Classic PH/PHX-25

MATERIAL HEATER

WARNING! Before performing any maintenance, make sure the Main Power Switch is OFF and incoming power is locked OFF. NEVER access the inside of the Control Panel with the Proportioner power supply ON. The Heaters are components that reach high temperatures; you must wait until they have cooled before handling and bleed all material pressure to zero.



Thermocouple Replacement

NOTE! The Thermocouple is assembled into the Connector Body with a Ferrule and Nut. Once inserted into the Body and the Nut is tightened, the Ferrule locks to the Thermocouple and does not allow it to be relocated or moved. The location of the Thermocouple is very important and must be done correctly before tightening the Nut.

1. Unscrew the Nut that holds the defective Thermocouple and remove from the Body. Disconnect Thermocouple wiring located under the Top Cover of the Heater. Remove Body and discard.
2. Install Connector Body into Heater using an open-end wrench and tighten to prevent leakage. Teflon Tape or appropriate Thread Sealant should be used.
3. Slide the Nut and the Ferrule over the Thermocouple and insert this assembly into the Connector Body until it comes into **positive physical contact** with the Heating Rod. Make sure the Spring does not prevent the Thermocouple from making contact with the Heating Rod.
4. Slowly tighten the Nut using an open-end wrench (9/16"), ensuring the Thermocouple maintains positive physical contact with the Heating Rod.
5. Reinstall the Thermocouple wires.

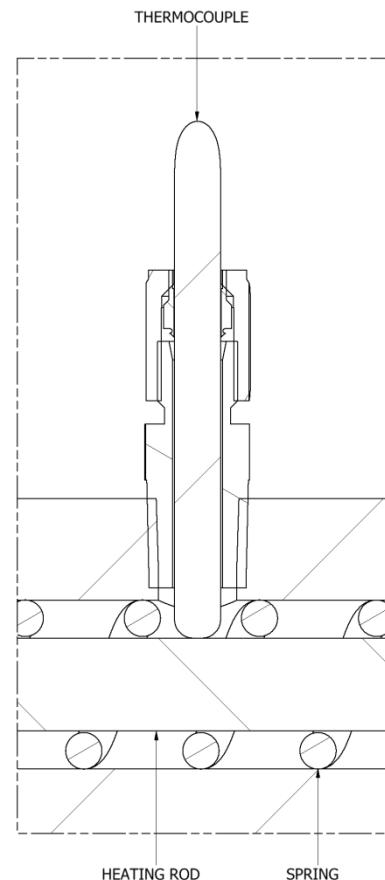
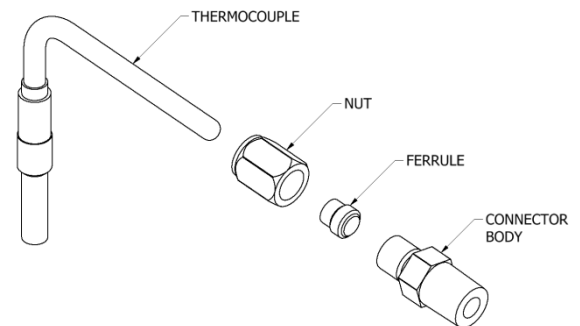



Classic PH/PHX-25

WARNING! Before performing any maintenance, make sure the Main Power Switch is OFF and incoming power is locked OFF. NEVER access the inside of the Control Panel with the Proportioner power supply ON. The Heaters are components that reach high temperatures; you must wait until they have cooled before handling and bleed all material pressure to zero.



Heating Rod

To replace defect Heating Rod proceed as follows:

1. Ensure Main Power Switch is OFF and incoming power is locked OFF. Depressurize the proportioner and remove the Cover from the Heater.

WARNING! If the Heating Rod to be replaced is the one in contact with the Thermocouple, it is necessary to remove the Thermocouple first (see page 46). Do not loosen or tighten Thermocouple Body.

2. Disconnect the suspect Heating Rod from the wire connections and test Heating Rod for proper electrical resistance.

HEATING ROD	INDIVIDUAL OHMS MEASUREMENT	TOTAL OHMS MEASUREMENT
1250 WATT	39.0 Ω	6.5 Ω
1500 WATT	32.4 Ω	5.4 Ω
1750 WATT	27.5 Ω	4.6 Ω

*Measurements taken at room temperature.

3. Unscrew the Heating Rod and remove from the Heater Block along with its Spring and inspect; it must be smooth and shiny in appearance. If it is blackened or has material adhered to it replace the Heating Rod even if ohm reading is acceptable.
4. Apply Teflon Tape or appropriate Thread Sealant to the Heating Rod thread and assemble Heating Rod and Spring into the Heater Block. Tighten securely to 110 ft/lbs.
5. If necessary carefully re-install Thermocouple ensuring **positive physical contact** with the Heating Rod. Make sure the Spring does not prevent the Thermocouple from making contact with the Heating Rod. Tighten Nut with open-end wrench (9/16”).
6. Reconnect wire connections and reinstall Heater Cover.
7. Ensure Heater is full of material prior to electrical testing.



Classic PH/PHX-25

REPLACEMENT KITS

120 Iso Pump Rebuild Kit, KT-05001-120		
Part Number	Description	QTY
OR-00011A	O-ring	2
OR-00020A	O-ring	2
OR-00044A	O-ring	1
OR-00045A	O-ring	1
OR-00046A	O-ring	2
OR-00051B	O-ring	1
PU-01001A-B12	Cylinder Bearing	1
PU-01013A	Flange Gasket	1
PU-01014A-012	Piston Support Washer	1
PU-01015A-012	Piston Seal Wiper	1
PU-01016A-012	Piston Seal	1
PU-01017A-012	Cylinder Seal	1
PU-05029	Pin	1

120 Poly Pump Rebuild Kit, KT-05002-120		
Part Number	Description	QTY
OR-00011A	O-ring	2
OR-00045A	O-ring	2
OR-00046A	O-ring	2
OR-00051B	O-ring	1
PU-01002-B12	Cylinder Bearing	1
PU-01013A	Flange Gasket	1
PU-01014A-012	Piston Support Washer	1
PU-01015A-012	Piston Seal Wiper	1
PU-01016A-012	Piston Seal	1
PU-01017A-012	Cylinder Seal	1
PU-05029	Pin	1



Classic PH/PHX-25

80 Iso Pump Rebuild Kit, KT-05001-080		
Part Number	Description	QTY
OR-00011A	O-ring	2
OR-00020A	O-ring	2
OR-00044A	O-ring	1
OR-00045A	O-ring	2
OR-00046A	O-ring	2
OR-00051B	O-ring	1
PU-01001A-B08	Cylinder Bearing	1
PU-01013A	Flange Gasket	1
PU-01014A-008	Piston Support Washer	1
PU-01015A-008	Piston Seal Wiper	1
PU-01016A-008	Piston Seal	1
PU-01017A-008	Cylinder Seal	1
PU-05029-80	Pin	1

80 Poly Pump Rebuild Kit, KT-05002-080		
Part Number	Description	QTY
OR-00011A	O-ring	2
OR-00045A	O-ring	2
OR-00046A	O-ring	2
OR-00051B	O-ring	1
PU-01002-B08	Cylinder Bearing	1
PU-01013A	Flange Gasket	1
PU-01014A-008	Piston Support Washer	1
PU-01015A-008	Piston Seal Wiper	1
PU-01016A-008	Piston Seal	1
PU-01017A-008	Cylinder Seal	1
PU-05029-80	Pin	1



Classic PH/PHX-25

Hydraulic Cylinder Rebuild Kit, KT-05025		
Part Number	Description	QTY
HI-05025-1	U-Cup	2
HI-05025-2	Back-up Ring, Piston	2
HI-05025-3	Wear Ring	1
HI-05025-4	Rod Wiper	2
HI-05025-5	Shaft Seal	2
HI-05025-6	Back-up Ring, Bushing	2
OR-00038A	O-ring	2
OR-00039A	O-ring	2
OR-00040A	O-ring	2

Proportioning Pump Line O-ring Kit, KT-05009		
Part Number	Description	QTY
OR-00011A	O-ring	4
OR-00046A	O-ring	4
OR-00045A	O-ring	4
OR-00051B	O-ring	2
PU-01013A	Gasket	2
OR-00044A	O-ring	1
OR-00020A	O-ring	2



Classic PH/PHX-25

Bleed System, KT-05003A		
Part Number	Description	QTY
GP-00100-1	Nipple	2
GP-00100-2	Ball Valve, 5,000 psi	2
GP-00100-4	Pipe Plug	2

Iso Lube Reservoir/Hose Kit, KT-05004		
Part Number	Description	QTY
RA-00068A	Check Valve	1
TN-04196	Hose Clamp	1
MQ-01009-01A	Reservoir Bottle	1
MQ-01009-02A	Reservoir Bottle Lid	1
MA-00024A	Return Tubing	1
MA-00025A	Supply Tubing	1

PMC Recommended Lube		
PART NUMBER	QTY	DESCRIPTION
GP-00960-1-QRT	1	Pump Lube Quart
GP-00960-1-GAL	1	Pimp Lube Gallon

Heater Thermocouple Kit, KT-05021		
Part Number	Description	QTY
HI-05020	Body, Nut, Ferrule	1
HI-05021	Thermocouple	1



Classic PH/PHX-25

HYDRAULIC OIL SPECIFICATIONS

Recommended Hydraulic Oil Specification:

ISO/ASTM Viscosity Grade 32

Viscosity: 28.8 – 35.2 SSU@ 104° F

Rust and Oxidation Inhibited

Manufacturers:

- Mobile DTE24 (Recommended)
- Cook's Albavis 8
- Ashland-Valvoline AW15
- Shell – Tellus 32(25)
- Sun Oil- Sunvis 706
- Chevron ISO32
- American Oil & Supply – PQ Iso 32
- Gulf Oil – Harmony 32AW (43AW)
- Atlantic Richfield – Duro AWS-150
- BP Oil – Energol HLP-C32
- Exxon – Nuto H-32(44)
- A. Margolis – T.I.P.100-15-7
- Fiske Bros. – Lubriplate Hyd. #0
- SW – Alemite Hydraulic HD#0
- Texaco – Rando HD32 (HD A0)
- White & Bagley – EP Hyd. 150



Classic PH/PHX-25

PART IDENTIFICATION

PUMPLINE ASSEMBLY (PL-1A/PL-2)

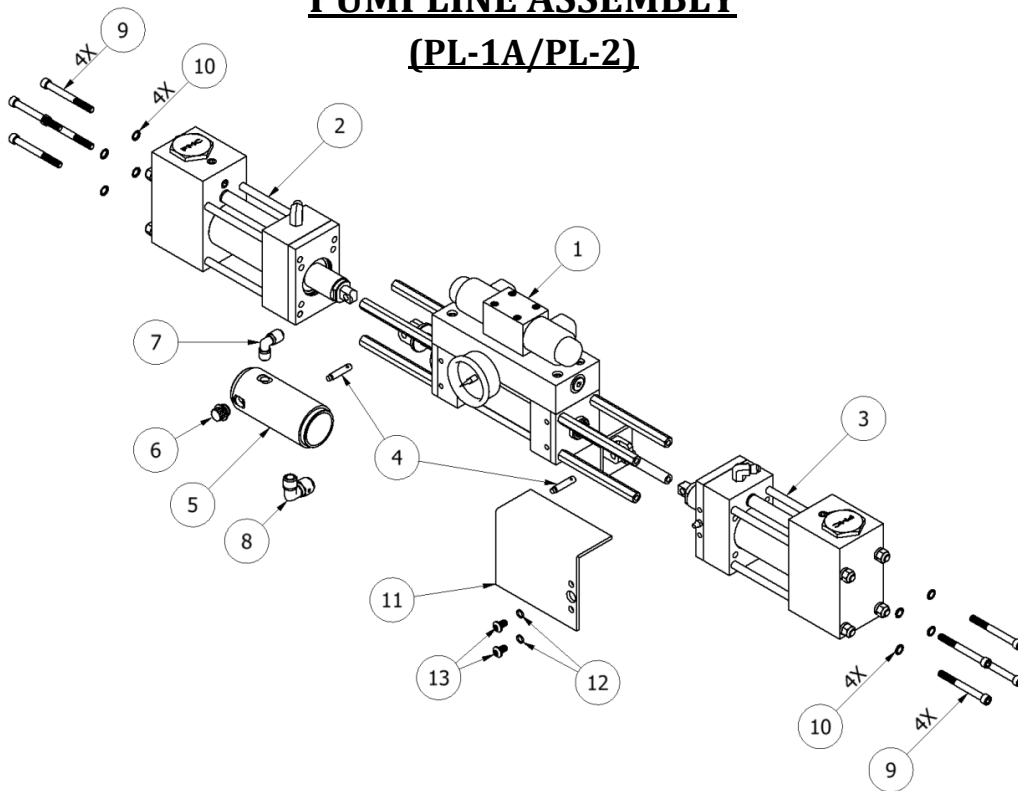

PUMPLINE ASSEMBLY (PL-1A/PL-2)			
ITEM	QTY	PART NUMBER	DESCRIPTION
1	1	HI-01	HYDRAULIC CYLINDER COMPLETE (SEE PAGE 54)
2	1	PU-05001-120	"A" PUMP ASSEMBLY, SIZE 120 (SEE PAGE 59)
	1	PU-05001-80	"A" PUMP ASSEMBLY, SIZE 80 (SEE PAGE 60)
3	1	PU-05002-120	"R" PUMP ASSEMBLY, SIZE 120 (SEE PAGE 58)
	1	PU-05001-80	"R" PUMP ASSEMBLY, SIZE 80 (SEE PAGE 58)
4	2	PU-05007	CLEVIS PIN
5	1	PU-05003	LUBE CYLINDER
6	1	RA-00065A	PUMP CYLINDER PLUG
7	1	RA-00066A	MALE ELBOW 3/8 X 1/4
8	1	RA-00067A	MALE ELBOW 1/2 X 3/8
9	8	PU-05008	MOUNTING BOLT
10	8	PU-05008-1	SERRATED WASHER 5/16
11	1	PU-01027	ACTIVATOR PLATE COVER
12	2	FLOOR STOCK	011 O-RING
13	2	FLOOR STOCK	5/16-18 X 0.5 BHCS



Classic PH/PHX-25

HYDRAULIC CYLINDER COMPLETE

(HI-01)

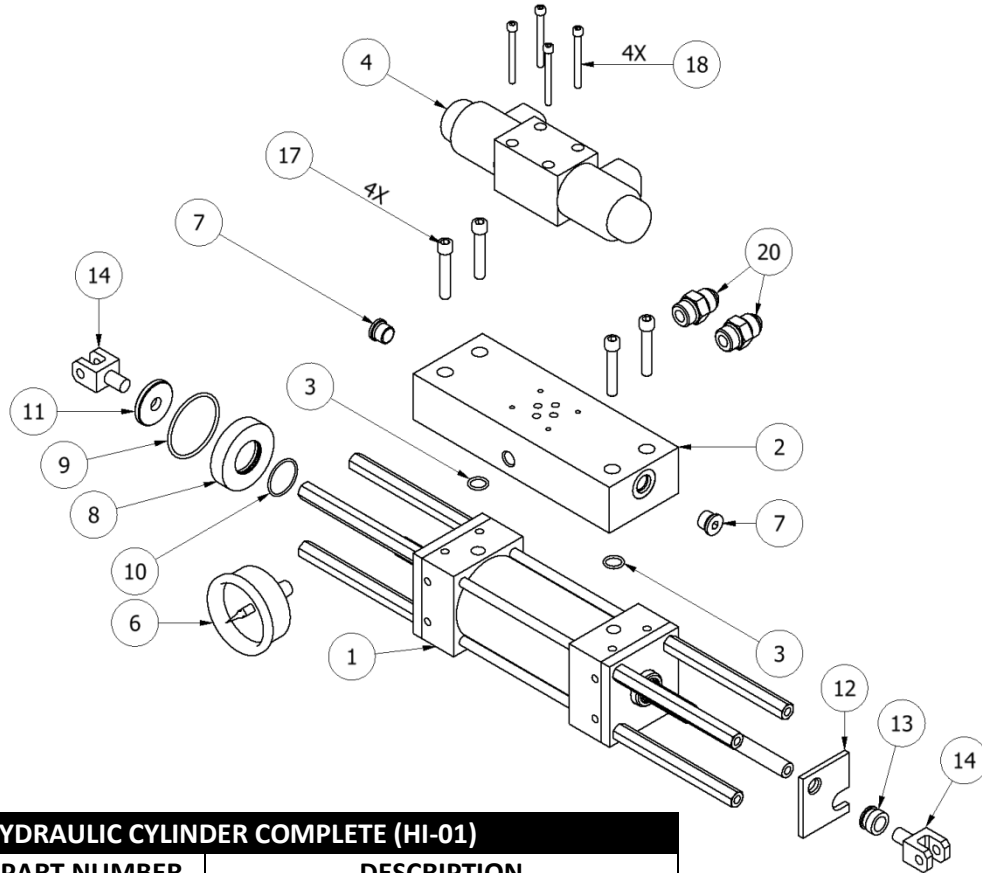

HYDRAULIC CYLINDER COMPLETE (HI-01)			
ITEM	QTY	PART NUMBER	DESCRIPTION
1	1	HI-05025A	HYDRAULIC CYLINDER ASSEMBLY (SEE PAGE 55)
2	1	HI-05070	HYDRAULIC MANIFOLD; CLASSIC
3	2	OR-00038A	2MMX12.5MM. 75 VITON BROWN
4	1	HI-05003	DIRECTIONAL VALVE
6	1	HI-05040	PRESSURE GUAGE 0-2000 PSI
7	2	HI-05070-4	HEX SOCKET O-RING BOSS
8	1	PU-05004	END CAP; CYLINDER
9	1	OR-00020A	#136 VITON LUBE CYLINDER O-RING
10	1	OR-00044A	O-RING #024; LUBE CYLINDER
11	1	PU-05005	BAFFLE
12	1	PU-05009	PLATE; REVERSING SWITCH
13	1	PU-05010	BUSHING
14	2	PU-05006	CLEVIS; HYDRAULIC
17	4	FLOOR STOCK	5/16-18 X 1.75 SHCS
18	4	FLOOR STOCK	#10-24 X 2 SHCS
20	2	HI-05012	3/4-16 O-RING X 3/4-16 JIC NIP



Classic PH/PHX-25

HYDRAULIC CYLINDER ASSEMBLY

(HI-05025A)

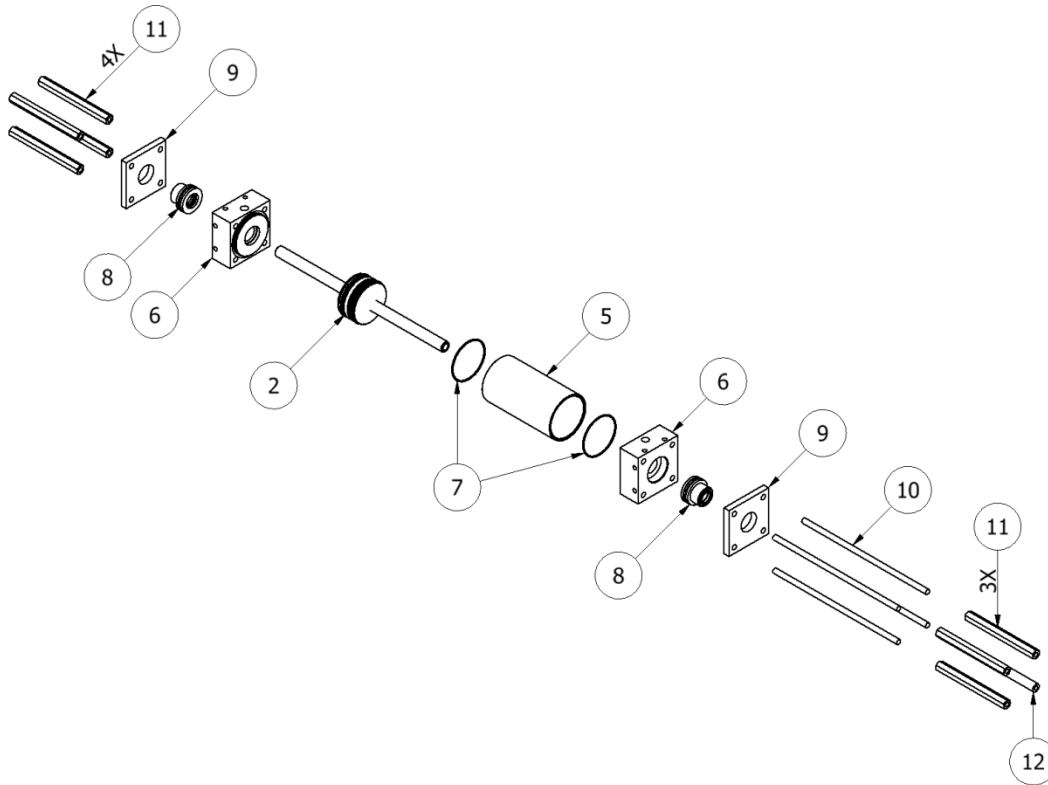

HYDRAULIC CYLINDER ASSEMBLY (HI-05025A)			
ITEM	QTY	PART NUMBER	DESCRIPTION
2	1	-	HYDRAULIC PISTON ASSEMBLY (SEE PAGE 57)
5	1	HI-05025-8	HYDRAULIC CYLINDER
6	2	HI-05025-9	PORT BLOCK; HYDRAULIC
7	2	OR-00040A	O-RING #36; HYD CYLINDER
8	2	-	HYDRAULIC SEAL ASSEMBLY (SEE PAGE 56)
9	2	HI-05025-10	RETAINER FLANGE
10	4	HI-05025-14	TIE ROD; 5/16-24
11	7	HI-05025-11	HYDRAULIC STANDOFF
12	1	HI-05025-12	REVERSING SWITCH STANDOFF



Classic PH/PHX-25

HYDRAULIC SEAL ASSEMBLY

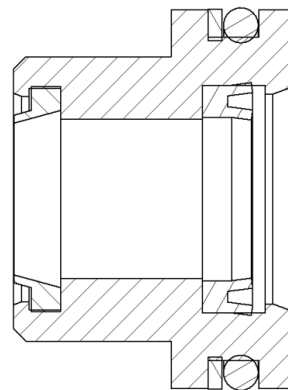
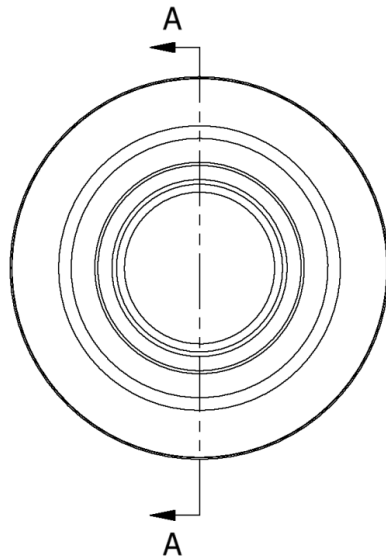
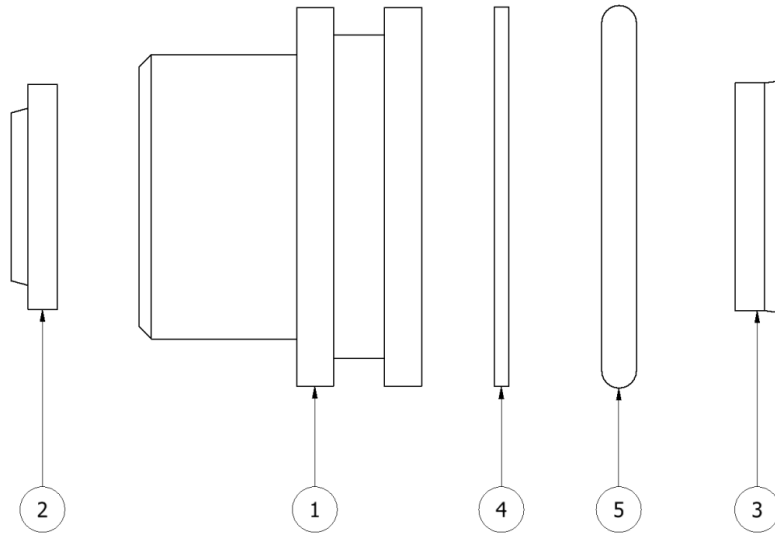

SECTION A-A
SCALE 2 : 1

HYDRAULIC SEAL ASSEMBLY			
ITEM	QTY	PART NUMBER	DESCRIPTION
1	2	HI-05025-13	BUSHING; ROD
2	2	HI-05025-4	ROD WIPER
3	2	HI-05025-5	SHAFT SEAL
4	2	HI-05025-6	BACK-UP RING; BUSHING
5	2	OR-00039A	O-RING #218 HYD CYLINDER ROD



Classic PH/PHX-25

HYDRAULIC PISTON ASSEMBLY

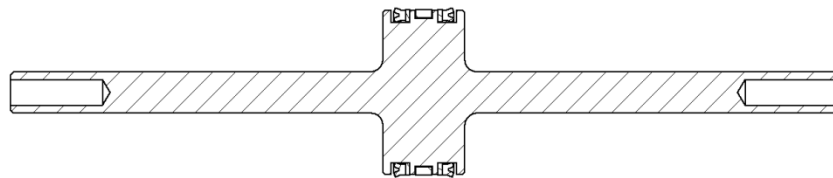
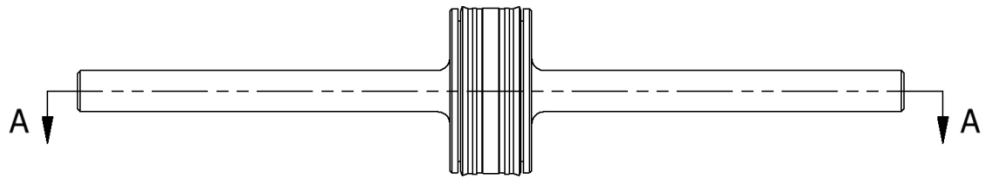
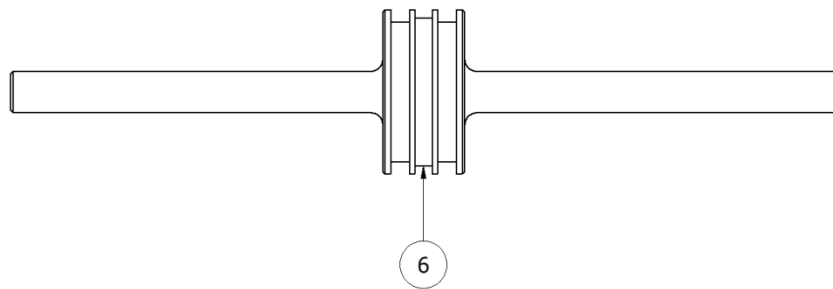
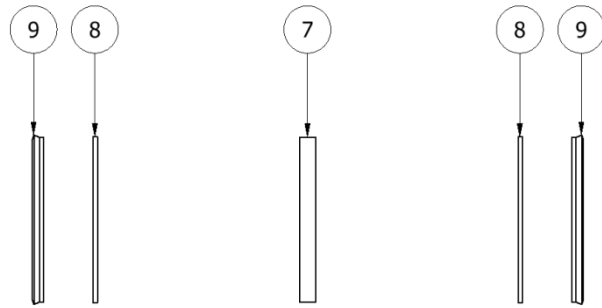

HYDRAULIC PISTON ASSEMBLY			
ITEM	QTY	PART NUMBER	DESCRIPTION
6	1	HI-05025-7	HYDRAULIC PISTON
7	1	HI-05025-3	WEAR RING
8	2	HI-05025-2	BACK UP RING; PISTON
9	2	HI-05025-1	U CUP



Classic PH/PHX-25

"R" PUMP ASSEMBLY; SIZE 120 & 80

(PU-05002-120 & PU-05002-80)

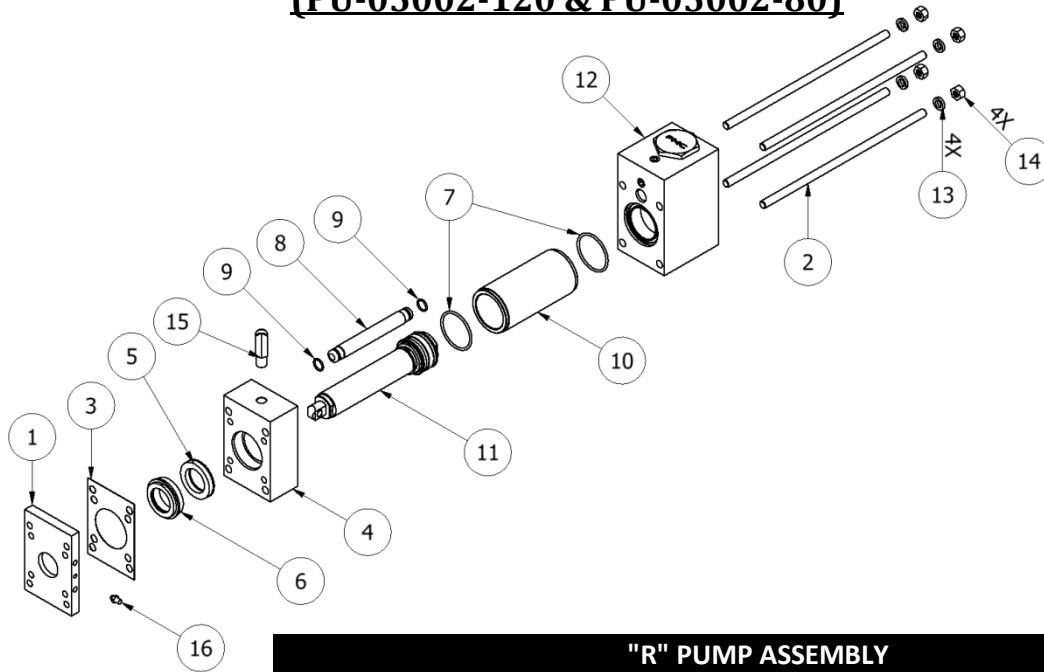

"R" PUMP ASSEMBLY			
ITEM	QTY	PART NUMBER	DESCRIPTION
1	1	PU-05032	"R" PACKING RETAINER FLANGE; SIZE 120
	1	PU-05032-80	"R" PACKING RETAINER FLANGE; SIZE 80
2	4	PU-05026	TIE ROD; 3/8-24
3	1	PU-01013A	CYLINDER FLANGE GASKET
4	1	PU-05014	PUMP FLANGE; SIZE 120
	1	PU-05014-80	PUMP FLANGE; SIZE 80
5	1	PU-01017A-012	120 PUMP CYLINDER SEAL
	1	PU-01017A-008	80 PUMP CYLINDER SEAL
6	1	PU-01002-B12	"R" CYLINDER BEARING; SIZE 120
	1	PU-01002-B08	"R" CYLINDER BEARING; SIZE 80
7	2	OR-00046A	O-RING #133; VITON 90D PUMP CYL
8	1	PU-05017	CROSSOVER TUBE
9	2	OR-00011A	O-RING; CROSSOVER TUBE #014
10	1	PU-05012	CYLINDER; SIZE 120
	1	PU-05012-80	CYLINDER; SIZE 80
11	1	-	PISTON ASSEMBLY (SEE PAGE 61)
12	1	-	PUMP BASE ASSEMBLY (SEE PAGE 62)
13	4	PU-05027	WASHER
14	4	FLOOR STOCK	3/8-24 HEX BOLT
15	1	HI-05038	1/4 NPT X 9/16-18 JIC 90 DEG E
16	1	TN-04186	GREASE FITTING



Classic PH/PHX-25

"A" PUMP ASSEMBLY; SIZE 120

(PU-05001-120)

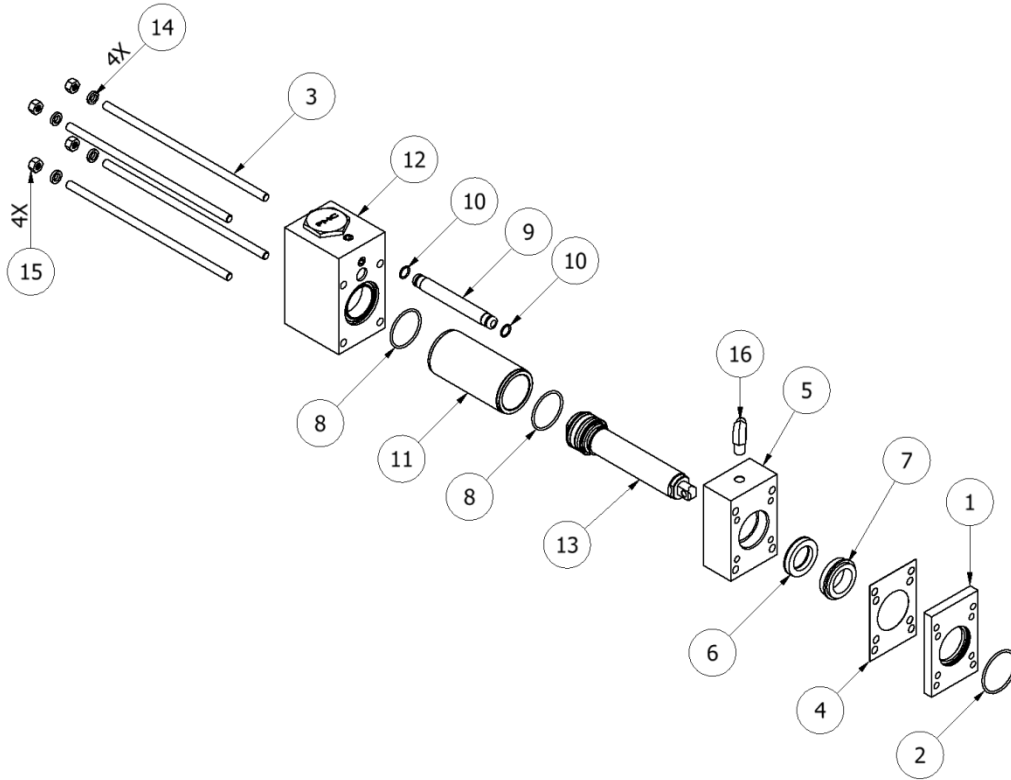

"A" PUMP ASSEMBLY; SIZE 120			
ITEM	QTY	PART NUMBER	DESCRIPTION
1	1	PU-05013	"A" PACKING RETAINER FLANGE
2	1	OR-00020A	#136 VITON LUBE CYLINDER O-RING
3	4	PU-05026	TIE ROD; 3/8-24
4	1	PU-01013A	CYLINDER FLANGE GASKET
5	1	PU-05014	PUMP FLANGE
6	1	PU-01017A-012	120 PUMP CYLINDER SEAL
7	1	PU-01001A-B12	"A" CYLINDER BEARING
8	2	OR-00046A	O-RING #133; VITON 90D PUMP CYL
9	1	PU-05017	CROSSOVER TUBE
10	2	OR-00011A	O-RING; CROSSOVER TUBE #014
11	1	PU-05012	CYLINDER
12	1	-	PUMP BASE ASSEMBLY (SEE PAGE 62)
13	1	-	PISTON ASSEMBLY (SEE PAGE 61)
14	4	PU-05027	WASHER
15	4	FLOOR STOCK	3/8-24 HEX BOLT
16	1	HI-05038	1/4 NPT X 9/16-18 JIC 90 DEG E



Classic PH/PHX-25

"A" PUMP ASSEMBLY; SIZE 80

(PU-05001-80)

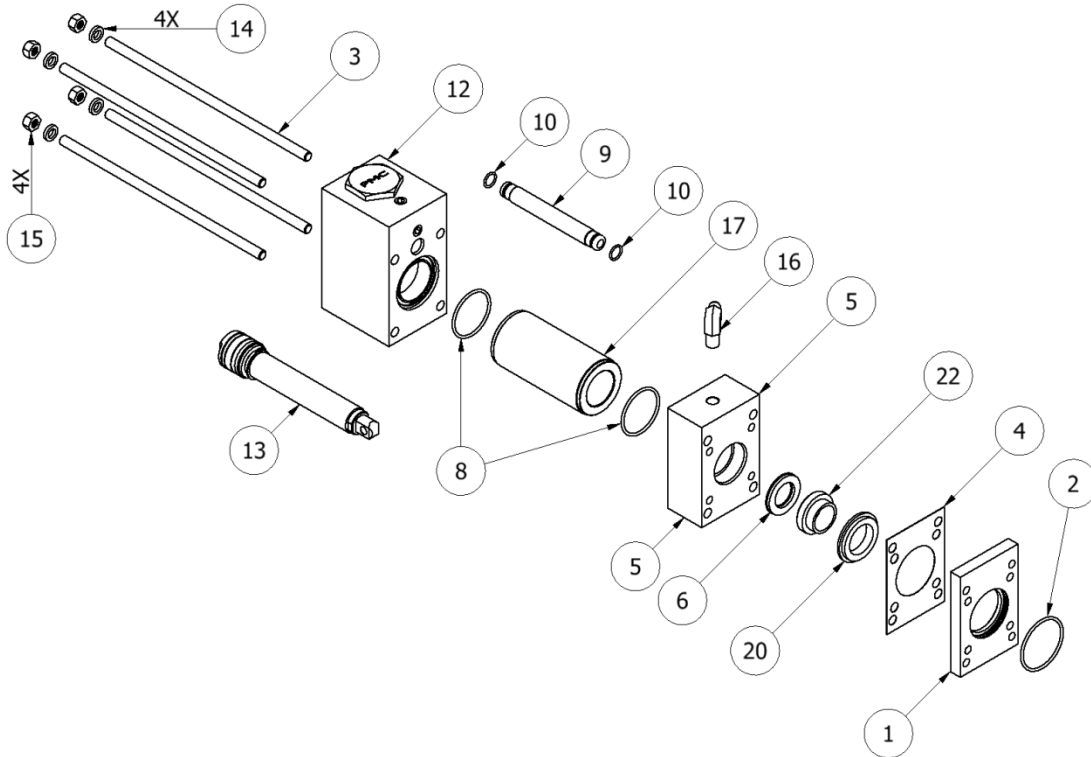

"A" PUMP ASSEMBLY; SIZE 80			
ITEM	QTY	PART NUMBER	DESCRIPTION
1	1	PU-05013	"A" PACKING RETAINER FLANGE
2	1	OR-00020A	#136 VITON LUBE CYLINDER O-RING
3	4	PU-05026	TIE ROD; 3/8-24
4	1	PU-01013A	CYLINDER FLANGE GASKET
5	1	PU-05014-80	PUMP FLANGE
6	1	PU-01017A-008	120 PUMP CYLINDER SEAL
8	2	OR-00046A	O-RING #133; VITON 90D PUMP CYL
9	1	PU-05017	CROSSOVER TUBE
10	2	OR-00011A	O-RING; CROSSOVER TUBE #014
12	1	-	PUMP BASE ASSEMBLY (SEE PAGE 62)
13	1	-	PISTON ASSEMBLY (SEE PAGE 61)
14	4	PU-05027	WASHER
15	4	FLOOR STOCK	3/8-24 HEX BOLT
16	1	HI-05038	1/4 NPT X 9/16-18 JIC 90 DEG E
17	1	PU-05012-80	CYLINDER
20	1	PU-01001A-C08	"A" RETAINER RING
22	1	PU-01001A-B08	"A" CYLINDER BEARING



Classic PH/PHX-25

PISTON ASSEMBLY

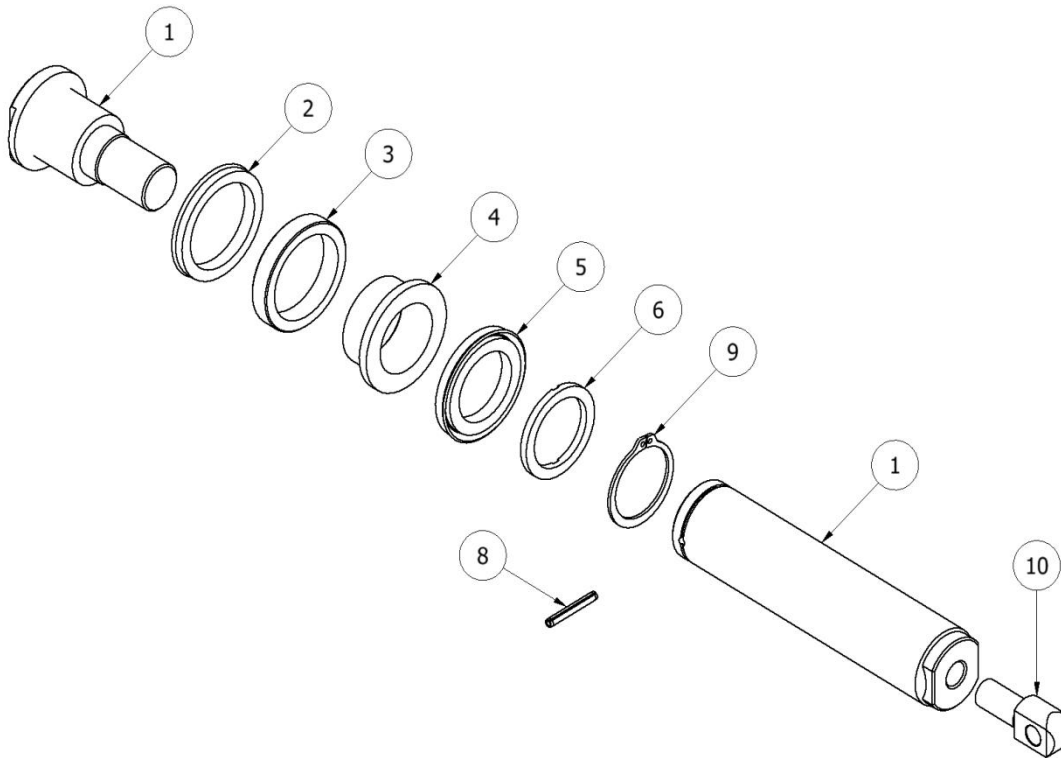

PISTON ASSEMBLY			
ITEM	QTY	PART NUMBER	DESCRIPTION
1	1	PU-05011-120	PISTON SHAFT; SIZE 120
	1	PU-05011-80	PISTON SHAFT; SIZE 80
2	1	PU-01015A-012	PISTON WIPER SEAL; SIZE 120
	1	PU-01015A-008	PISTON WIPER SEAL; SIZE 80
3	1	PU-01014A-012	WIPER RING; SIZE 120
	1	PU-01014A-008	WIPER RING; SIZE 80
4	1	PU-05016	PISTON SUPPORT BEARING; SIZE 120
	1	PU-05016-80	PISTON SUPPORT BEARING; SIZE 80
5	1	PU-01016A-012	PISTON SEAL; SIZE 120
	1	PU-01016A-008	PISTON SEAL; SIZE 80
6	1	PU-05015-120	PISTON SUPPORT WASHER; SIZE 120
	1	PU-05015-80	PISTON SUPPORT WASHER; SIZE 80
8	1	PU-05029	PIN; SIZE 120
	1	PU-05029-80	PIN; SIZE 80
9	1	PU-05030	SNAP RING; SIZE 120
	1	PU-05030-80	SNAP RING; SIZE 80
10	1	PU-05031	PISTON CLEVIS; SIZE 120
	1	PU-05031-80	PISTON CLEVIS; SIZE 80



Classic PH/PHX-25

PUMP BASE ASSEMBLY

PUMPBASE ASSEMBLY			
ITEM	QTY	PART NUMBER	DESCRIPTION
1	1	PU-05018	PUMP BASE
2	1	PU-01003-DG	INLET BALL SEAT GASKET
3	1	PU-05019	INLET SEAT
4	1	PU-05020	INLET BALL
5	1	PU-05021	SPRING
6	1	PU-05022A	SLEEVE
7	1	OR-00051B	#218 AFLAS 80D O-RING
8	1	PU-01003-IG	DISCHARGE BALL SEAT GASKET
9	1	PU-05024	DISCHARGE SEAT
10	1	PU-05025	DISCHARGE BALL
11	1	PU-05023-R	PUMP RETAINER NUT
12	1	PU-05023-1	GASKET
14	2	HI-05067	PIPE PLUG 1/4-18; 7/8 TAPER

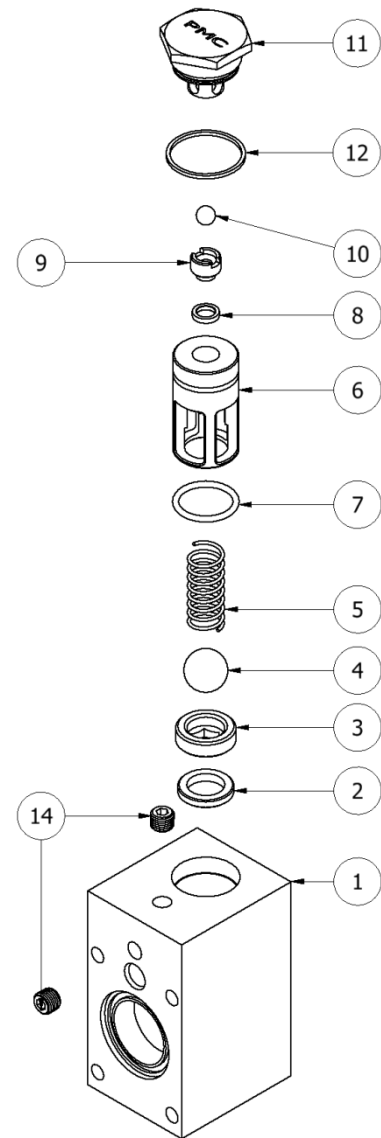



Classic PH/PHX-25

HEATER ASSEMBLY

(PH-1/PH-3/PH-11 & PH-2/PH-4/PH-12)

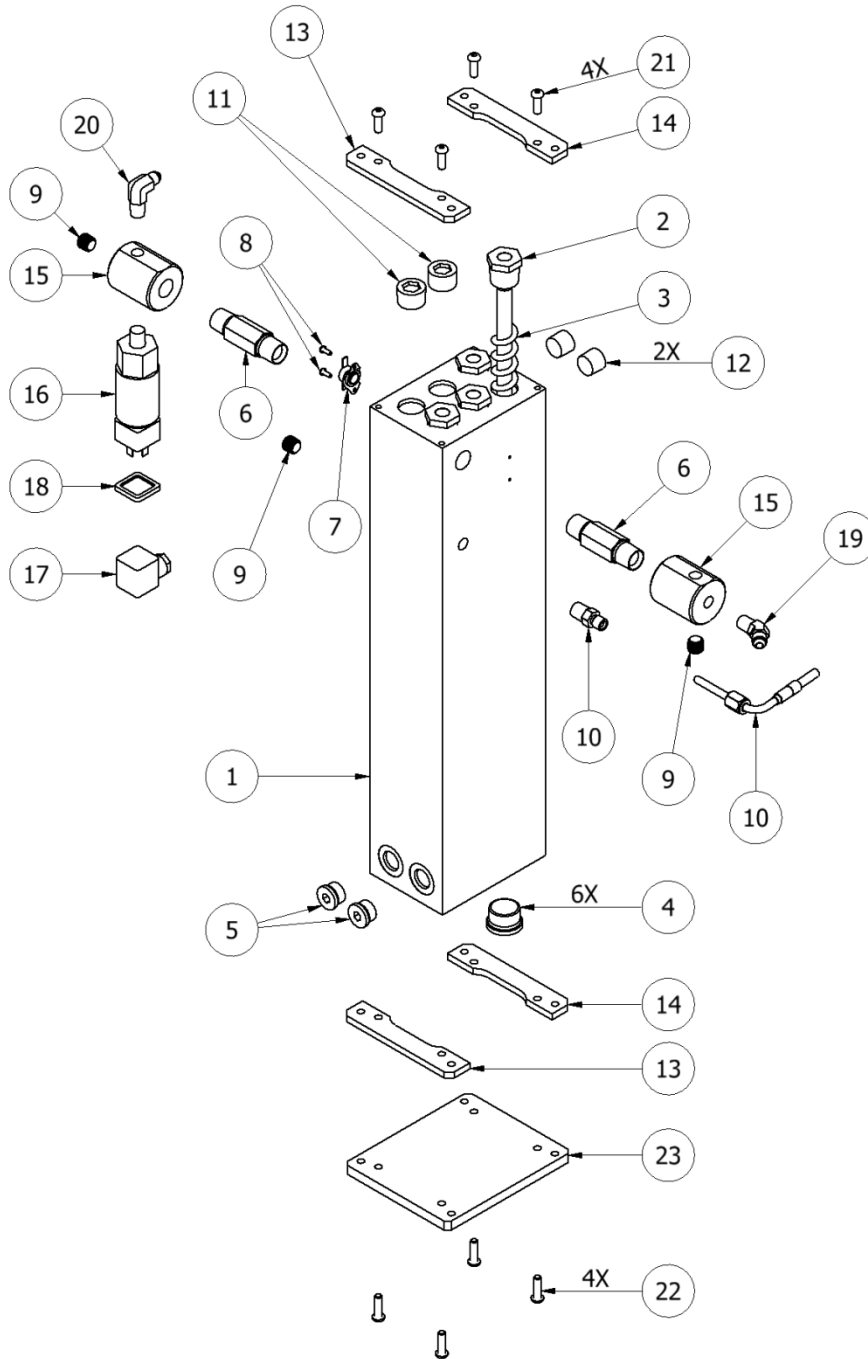



Classic PH/PHX-25

HEATER ASSEMBLY			
ITEM	QTY	PART NUMBER	DESCRIPTION
1	1	GM-05423-1	HEATER BODY
2	4	GM-05423-1000	FIRE ROD; 1000 WATT (PH-11/PH-12)
	4	GM-05423-1250	FIRE ROD; 1250 WATT (PH-1/PH-2)
	4	GM-05423-1500	FIRE ROD; 1500 WATT (PH-3/PH-4)
3	4	GM-05423-7	SPRING; 18IN CBN STEEL
4	6	HI-05034	1-1/16-12 O-RING PLUG
5	3	HI-05033	3/4-16 O-RING PLUG
6	2	HI-05032	1/2 NPT LONG HEX NIPPLE
7	1	EL-00006A	THERMAL LIMIT OVERTEMP SWITCH
8	2	FLOOR STOCK	#6-32 X .375 BHCS
9	3	HI-05036	1/4 NPT FLUSH SEAL PIPE PLUG
10	1	HI-05021	THERMOCOUPLE; TYPE E
11	2	HI-05037	3/4 NPT FLUSH SEAL PIPE PLUG
12	2	HI-05035	1/2 NPT FLUSH SEAL PIPE PLUG
13	2	GM-05423-9	PHENOLIC STANDOFF; FRONT
14	2	GM-05423-10	PHENOLIC STANDOFF; BACK
15	2	HI-05046	GUAGE MANIFOLD
16	1	EL-42-2200	PRESSURE SWITCH (PH)
	1	EL-42-3200	PRESSURE SWITCH (PHX)
17	1	EL-00052	SOLENOID VALVE CONNECTOR
18	1	EL-00053	GASKET
19	1	HI-05026	OUTLET HEATER FITTING "R"
	1	HI-05027	OUTLET HEATER FITTING "A"
20	1	HI-05038	1/4 NPT X 9/16-18 JIC 90 DEG ELBOW
21	4	FLOOR STOCK	1/4-20 X .75 BHCS
22	4	FLOOR STOCK	1/4-20 X .875 BHCS
23	1	RM-05700-17	HEATER BOTTOM; MOUNTING PLATE



Classic PH/PHX-25

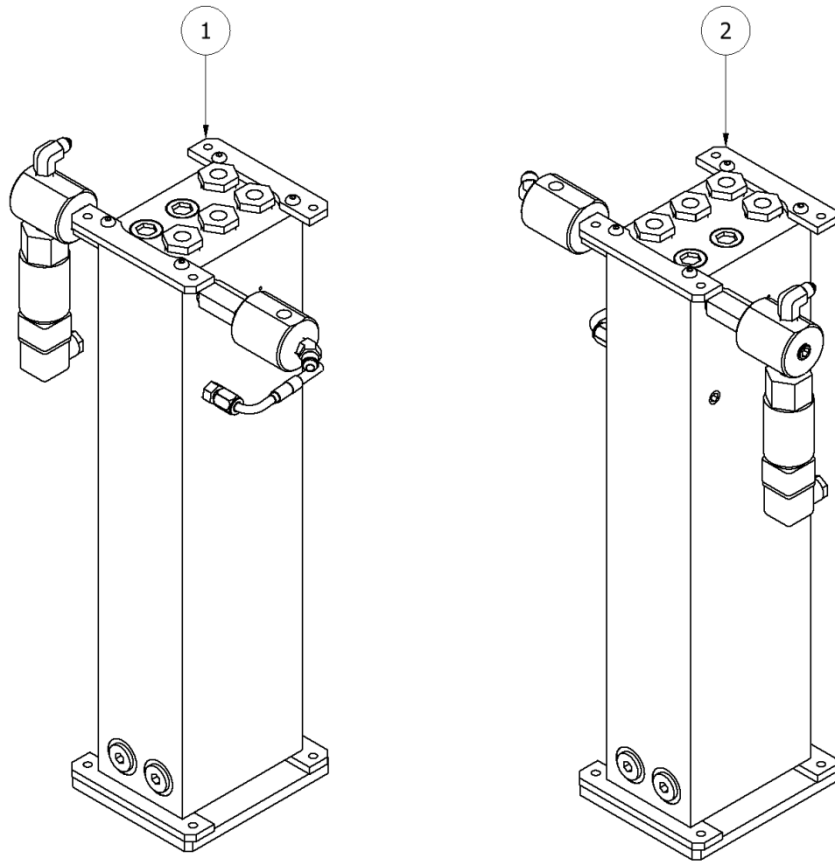

HEATER ASSEMBLY			
ITEM	QTY	PART NUMBER	DESCRIPTION
1	1	PH-1	HEATER ASSEMBLY "A" SIDE; 5 KW
	1	PH-3	HEATER ASSEMBLY "A" SIDE; 6 KW
	1	PH-11	HEATER ASSEMBLY "A" SIDE; 4 KW
2	1	PH-2	HEATER ASSEMBLY "R" SIDE; 5 KW
	1	PH-4	HEATER ASSEMBLY "R" SIDE; 6 KW
	1	PH-12	HEATER ASSEMBLY "R" SIDE; 4 KW

NOTE: "A" AND "R" SIDE HEATERS ARE MIRRORED. THE ONLY DIFFERENCE IN PARTS IS THE OULET FITTING (ITEM 19)



Classic PH/PHX-25

PRESSURE TRANSDUCER ASSEMBLY

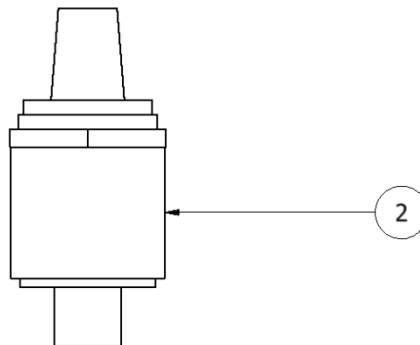
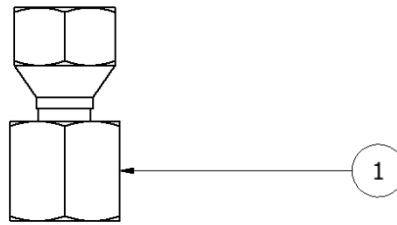
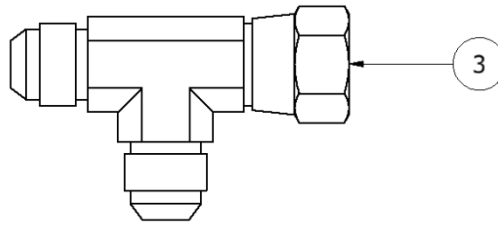

PRESSURE TRANSDUCER ASSEMBLY (EL-200)			
ITEM	QTY	PART NUMBER	DESCRIPTION
1	1	HI-05006-6	1/4 NPT X 6 JIC GUAGE FITTING
2	1	EL-195	0-5000 PRESSURE TRANSDUCER
3	1	HI-05006-5	6 JIC SWIVEL NUT RUN TEE



Classic PH/PHX-25

TRANSFORMER COVER ASSEMBLY

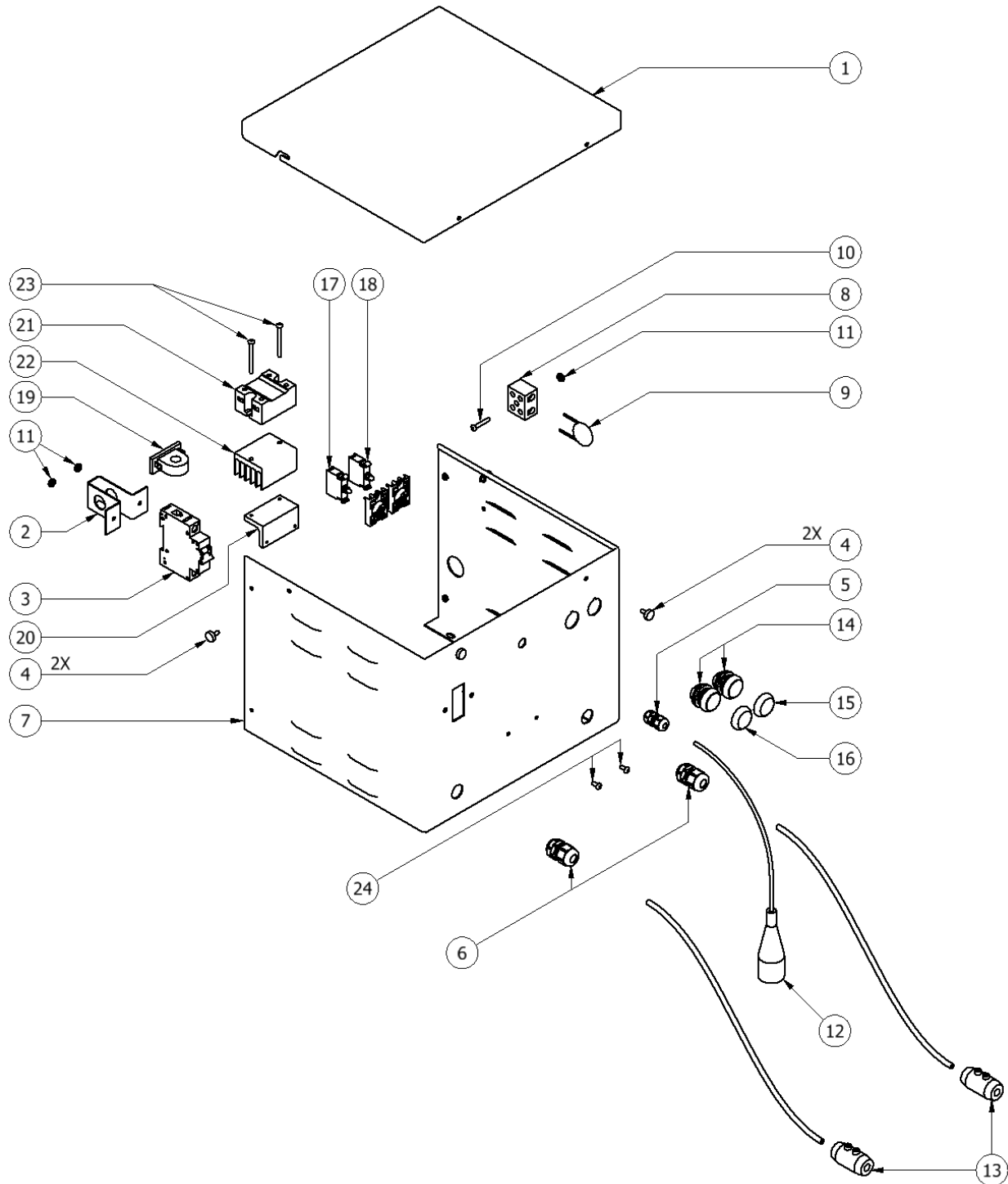



Classic PH/PHX-25

TRANSFORMER COVER ASSEMBLY			
ITEM	QTY	PART NUMBER	DESCRIPTION
1	1	RM-05700-26	TRANSFORMER COVER; TOP
2	1	EL-00118A-00-1	HOSE BREAKER MOUNTING PLATE
3	1	EL-150	CIRCUIT BRAKER, 63AMP
4	4	EL-05700-27	TRANSFORMER KNOB
5	1	EL-000P7	HAYCO SR
6	2	EL-000P12	HAYCO #6
7	1	RM-05700-25	TRANSFORMER COVER; SIDES
8	1	EL-192	TERMINAL BLOCK
9	1	EL-193	INRUSH CURRENT LIMITER
10	1	FLOOR STOCK	#8-32 X 1 PAN HEAD MACHINE SCREW
11	3	FLOOR STOCK	#8-32 HEX NUT
12	1	EL-05235	THERMOCOUPLE HARNESS; 24"
13	2	KT-00029A-1	HOSE HEAT; CONNECTOR BODY
14	2	EL-134	LIGHT SWITCH
15	1	EL-136	WHT LENS; "AMPS"
16	1	EL-137	RED LENS; "VOLTS"
17	1	EL-132-R	LIGHT UNIT; RED; 220VAC
18	1	EL-132-W	LIGHT UNIT; WHT; 220VAC
19	1	EL-37	TRANSFORMER; SIGNAL
20	1	EL-35-2	RELAY BRACKET
21	1	EL-35	HOSE HEAT RELAY
22	1	EL-35-1	HEAT SINK
23	2	FLOOR STOCK	#8-32 X 1-3/4 PAN HEAD MACHINE SCREW
24	2	FLOOR STOCK	#8-32 X 3/8 HEX SOCKET BUTTON HEAD CAP SCREW



Classic PH/PHX-25

Y-STRAINER ASSEMBLY

(YS-1 & YS-2)

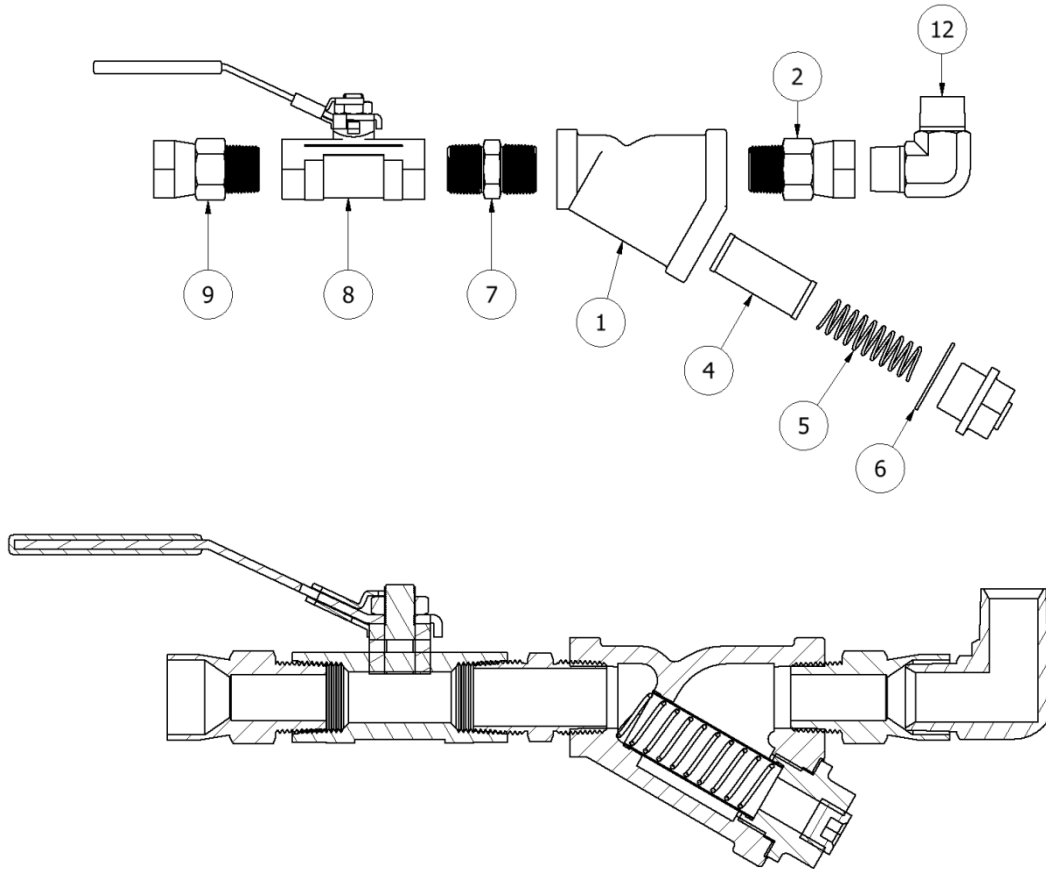

TRANSFORMER COVER ASSEMBLY			
ITEM	QTY	PART NUMBER	DESCRIPTION
1	1	RA-00074-00A	Y-STRAINER
2	1	HI-05016	3/4" SWIVEL FITTING
4	1	RA-00074-03-30A	REPLACEMENT SCREEN; 30 MESH
	1	RA-00074-03-60A	REPLACEMENT SCREEN; 60 MESH (STANDARD)
	1	RA-00074-03-80A	REPLACEMENT SCREEN; 80 MESH
5	1	SP-00009A	REPLACEMENT SPRING
6	1	RA-00074-02A	REPLACEMENT GASKET
7	1	HI-05017	3/4" HEX NIPPLE
8	1	RA-00078A	3/4" BALL VALVE
9	1	HI-05016	3/4" X 3/4" SWIVEL FITTING "R" SIDE
	1	HI-05018	3/4" X 1/2" SWIVEL FITTING "A" SIDE
12	1	HI-05015	3/4" NPT ELBOW



Classic PH/PHX-25

FRAME/TANK ASSEMBLY

(FR-1)

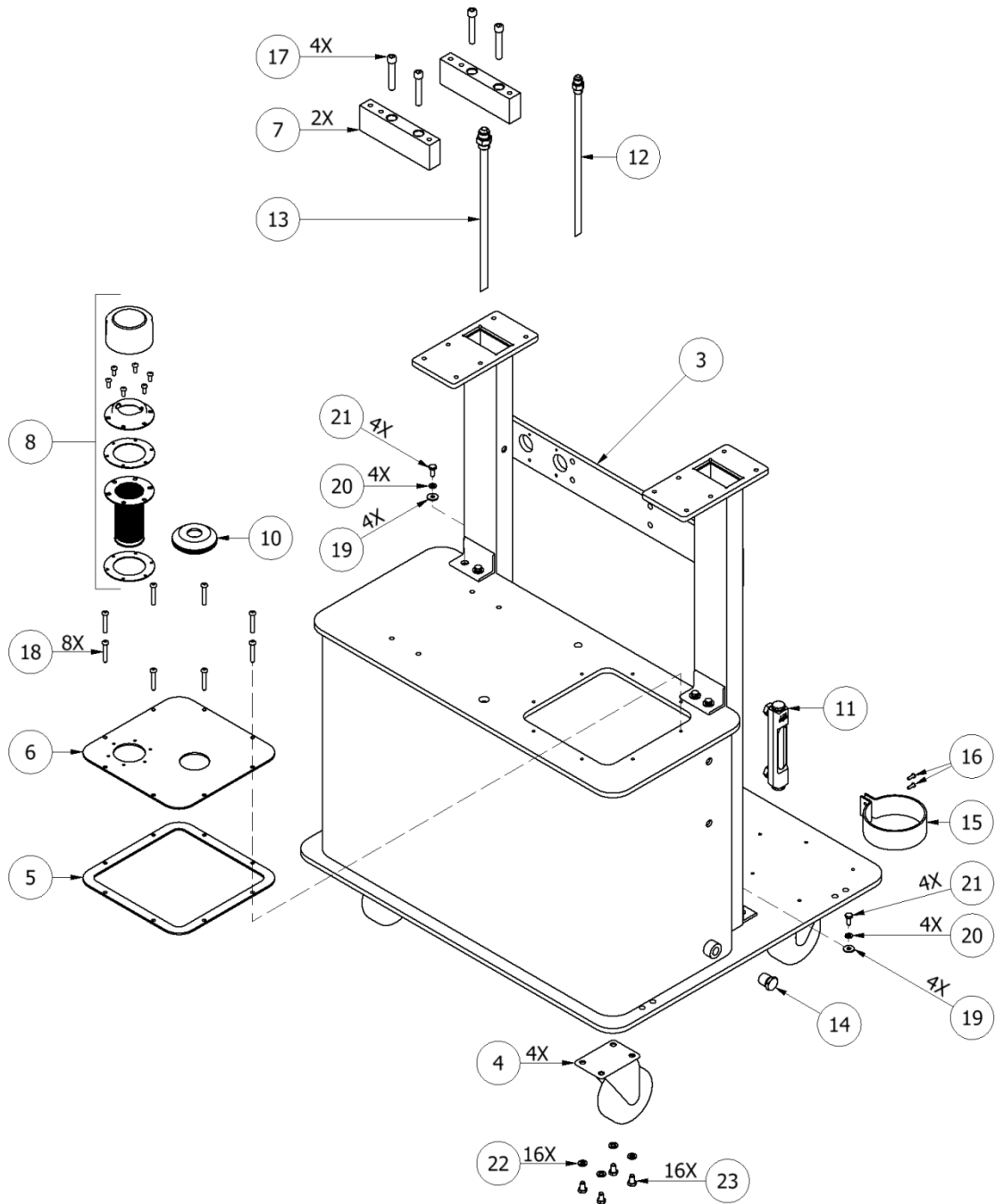



Classic PH/PHX-25

FRAME/TANK ASSEMBLY (FR-1)			
ITEM	QTY	PART NUMBER	DESCRIPTION
3	1	FR-2	UPRIGHT ASSEMBLY
4	4	TN-05704	4" SWIVEL CASTER
5	1	HI-00014-03A	TANK TOP GASKET
6	1	RM-05700-11	TANK LID
7	2	RM-05700-15	MOTOR MOUNT BARS
8	1	HI-00047A	FILL STRAINER WITH CAP
10	1	HI-00002-A	TANK TOP GROMMET
11	1	HI-00001A	SIGHT GUAGE
12	1	HI-05041	CASE DRAIN RETURN TUBE 3/8
13	1	HI-05042	CASE DRAIN RETURN TUBE 1/2
14	1	HI-05048	DRAIN PLUG
15	1	MQ-01008A	LUBE BRACKET
16	2	FLOOR STOCK	#8-32 X 0.5 BHCS
17	4	FLOOR STOCK	3/8-16 X 2.25 SHCS
18	8	FLOOR STOCK	1/4-20 X 1.5 BHCS
19	8	FLOOR STOCK	1/4 PLAIN WASHER
20	8	FLOOR STOCK	1/4 LOCK WASHER
21	8	FLOOR STOCK	1/4-20 X 5/8 HEX CAP SCREW
22	16	FLOOR STOCK	5/16 LOCK WASHER
23	16	FLOOR STOCK	5/16-18 X 1/2 HEX CAP SCREW



Classic PH/PHX-25

MOTOR LINE ASSEMBLY

(ML-1 & ML-2)

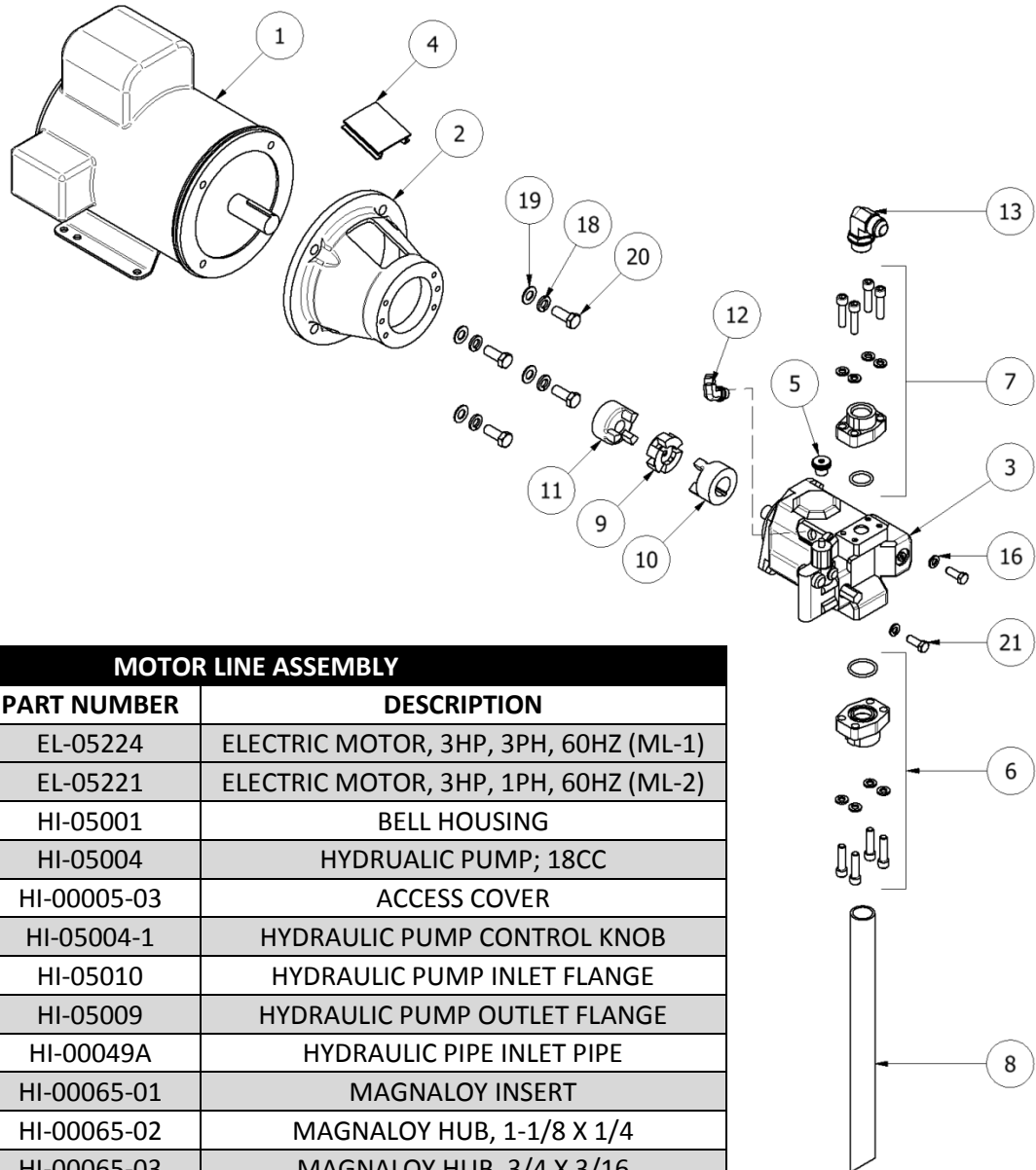

MOTOR LINE ASSEMBLY			
ITEM	QTY	PART NUMBER	DESCRIPTION
1	1	EL-05224	ELECTRIC MOTOR, 3HP, 3PH, 60HZ (ML-1)
	1	EL-05221	ELECTRIC MOTOR, 3HP, 1PH, 60HZ (ML-2)
2	1	HI-05001	BELL HOUSING
3	1	HI-05004	HYDRUALIC PUMP; 18CC
4	1	HI-00005-03	ACCESS COVER
5	1	HI-05004-1	HYDRAULIC PUMP CONTROL KNOB
6	1	HI-05010	HYDRAULIC PUMP INLET FLANGE
7	1	HI-05009	HYDRAULIC PUMP OUTLET FLANGE
8	1	HI-00049A	HYDRAULIC PIPE INLET PIPE
9	1	HI-00065-01	MAGNALOY INSERT
10	1	HI-00065-02	MAGNALOY HUB, 1-1/8 X 1/4
11	1	HI-00065-03	MAGNALOY HUB, 3/4 X 3/16
12	1	HI-05007	FITTING, 9/16-18 O-RING X 9/16-18 JIC
13	1	HI-05008	FITTING, 1-1/16 ORINGX 3/4-16 JIC
16	10	FLOOR STOCK	3/8 LOCK WASHER
17	8	FLOOR STOCK	3/8-16 X 1.5 SHCS
18	4	FLOOR STOCK	1/2 LOCK WASHER
19	4	FLOOR STOCK	1/2 PLAIN WASHER
20	4	FLOOR STOCK	1/2-13 X 1.25 Hex Cap Screw
21	2	FLOOR STOCK	3/8-16 X 1 Hex Cap Screw



Classic PH/PHX-25

TOP LEVEL ASSEMBLY

(PH-25/PHX-25)

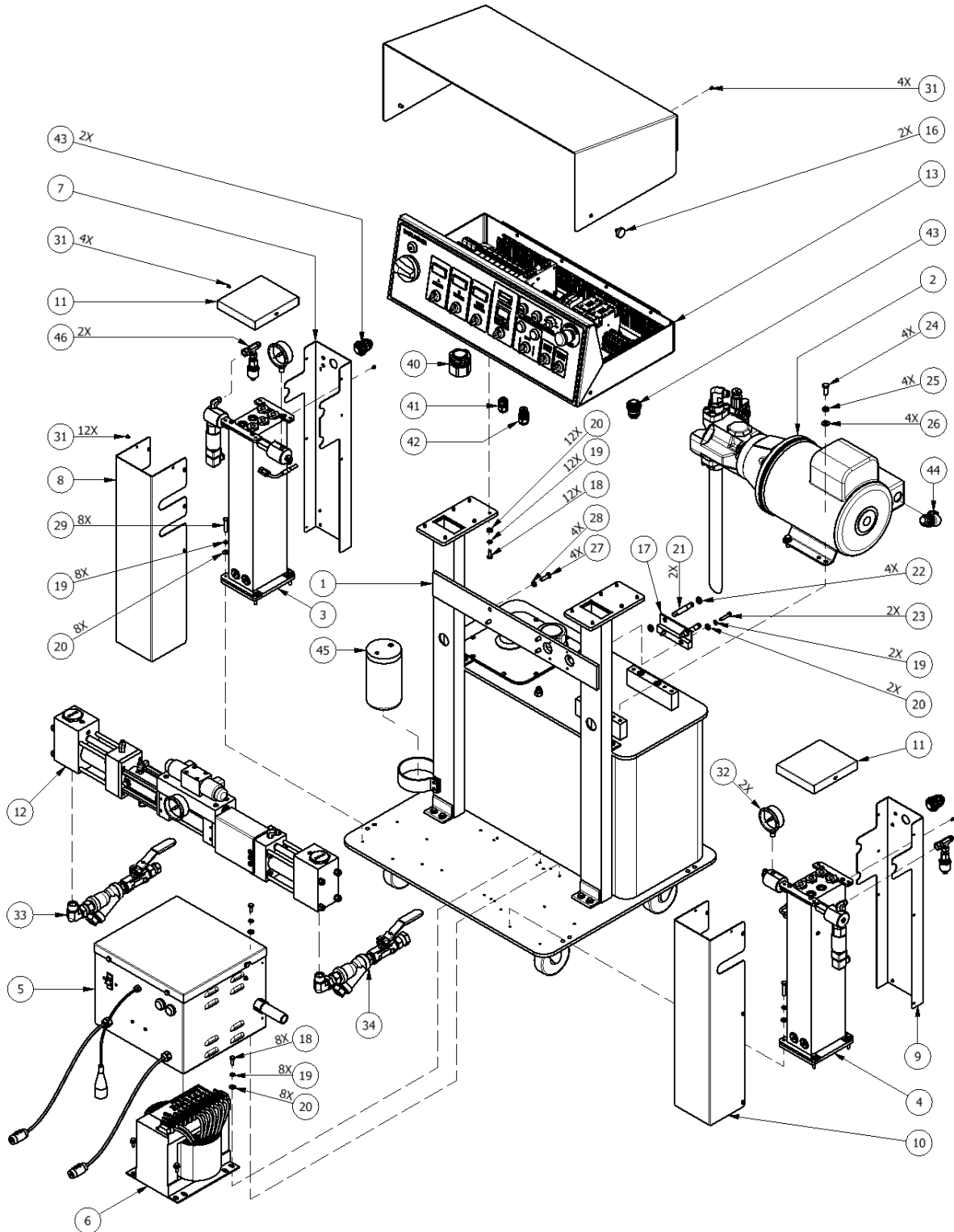



Classic PH/PHX-25

TOP LEVEL ASSEMBLY (PH-25/PHX-25)			
ITEM	QTY	PART NUMBER	DESCRIPTION
1	1	FR-1	FRAME/TANK ASSEMBLY (PAGE 70)
2	1	ML-1	MOTOR LINE ASSY; 3HP, 3PH, 60HZ (PAGE 72)
	1	ML-2	MOTOR LINE ASSY; 3HP, 1PH, 60HZ (PAGE 72)
3	1	PH-1	"A" SIDE HEATER, 5KW (PAGE 63)
	1	PH-3	"A" SIDE HEATER, 6KW (PAGE 63)
	1	PH-11	"A" SIDE HEATER, 4KW (PAGE 63)
4	1	PH-2	"R" SIDE HEATER, 5KW (PAGE 63)
	1	PH-4	"R" SIDE HEATER, 6KW (PAGE 63)
	1	PH-12	"R" SIDE HEATER, 4KW (PAGE 63)
5	1	-	TRANSFORMER COVER ASSEMBLY (PAGE 67)
6	1	EL-05225	90V TRANSFORMER
7	1	CL-02001-05A	"A" HEATER COVER; BACK
8	1	CL-02001-06A	"A" HEATER COVER; FRONT
9	1	CL-02002-05A	HEATER COVER; BACK
10	1	CL-02002-06A	"R" HEATER COVER; FRONT
11	2	CL-02001-07A	"R" HEATER COVER; TOP
12	1	PL-1A	PUMPLINE ASSEMBLY; 120 PUMPS (PAGE 53)
	1	PL-2	PUMPLINE ASSEMBLY; 80 PUMPS (PAGE 53)
13	1	EL-502-33	CONSOLE ASY; 3HP, 3PH
	1	EL-501-31	CONSOLE ASY; 3HP, 1PH
16	2	EL-05220-01	CONSOLE KNOBS
17	1	MQ-01005A	REVERSING SWITCH; MTG PLATE
18	20	FLOOR STOCK	1/4-20 X 3/4 HEX CAP SCREW
19	30	FLOOR STOCK	1/4 LOCK WASHER
20	30	FLOOR STOCK	1/4 PLAIN WASHER
21	2	EL-153	12MM PROX SWITCH
22	4	FLOOR STOCK	M10 X 1.5 HEX NUT
23	2	FLOOR STOCK	1/4-20 X 1-1/4 HEX CAP SCREW
24	4	FLOOR STOCK	3/8-16 X 1 HEX CAP SCREW
25	4	FLOOR STOCK	3/8 LOCK WASHER
26	4	FLOOR STOCK	3/8 PLAIN WASHER
27	4	FLOOR STOCK	5/16 X 1 HEX CAP SCREW
28	4	FLOOR STOCK	5/16 LOCK WASHER
29	8	FLOOR STOCK	1/4-20 X 1-1/2 HEX CAP SCREW
30	8	FLOOR STOCK	1/4-20 HEX NUT
31	32	FLOOR STOCK	#8-32 X 1/4 Hexagon Socket BHCS
32	2	HI-05028	GUAGE 0-3000 PSI (PH)
	2	HI-00035	GUAGE 0-5000 PSI (PHX)
33	1	YS-1	Y-STRAINER ASSEMBLY; "A" SIDE (PAGE 69)
34	1	YS-2	Y-STRAINER ASSEMBLY; "R" SIDE (PAGE 69)
40	1	EL-00088-01A	HEYCO SR INCOMING POWER
41	1	EL-000P12	HEYCO #6 AWG STRAIN RELIEF
42	1	EL-000P13	STRAIN RELIEF
43	3	EL-05230-02	STRAIGHT CONDUIT CONNECTOR
44	1	EL-05230-03	RT ANGLE CONDUIT CONNNECTOR
45	1	-	LUBE BOTTLE ASSEMBLY (PAGE 75)
46	2	EL-200	PRESSURE TRANSDUCER ASSEMBLY (PAGE 66)



Classic PH/PHX-25

LUBE BOTTLE COMPONENTS

PH-25

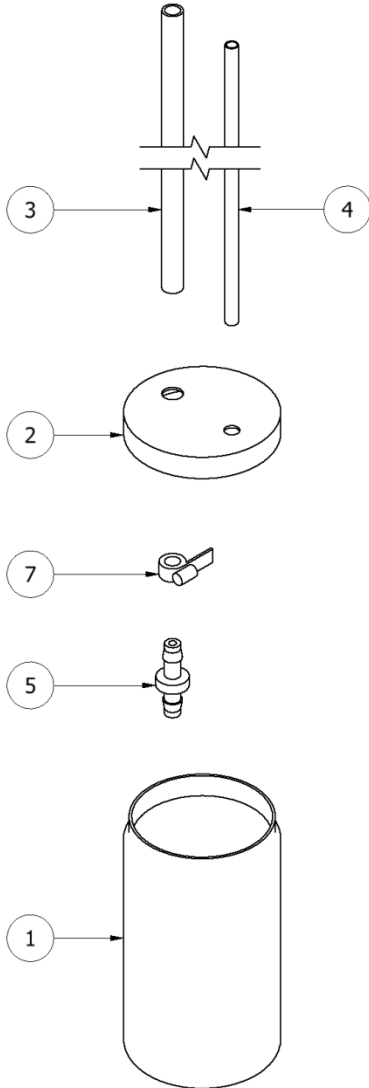

PHX-25

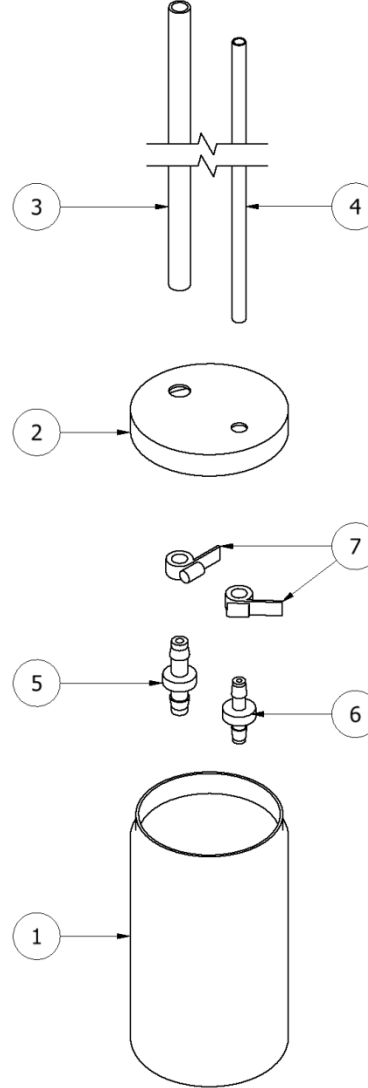

LUBE BOTTLE ASSEMBLY			
ITEM	QTY	PART NUMBER	DESCRIPTION
1	1	MQ-01009-01A	LUBE BOTTLE
2	1	MQ-01009-02A	LUBE BOTTLE LID
3	1	MA-00024A	1/2" X 3' PLASTIC TUBING RETURN
4	1	MA-00025A	3/8" X 3' PLASTIC TUBING SUPPLY
5	1	RA-00068A	CHECK VALVE
6	1	RA-06008	CHECK VALVE (PHX ONLY)
7	1	TN-04196	HOSE CLAMP (QTY=2 FOR PHX)
-	1	GP-00960-1-GAL	PUMP LUBE GALLON (NOT SHOWN)
-	1	GP-00960-1-QRT	PUMP LUBE QUART (NOT SHOWN)



Classic PH/PHX-25

HOSES

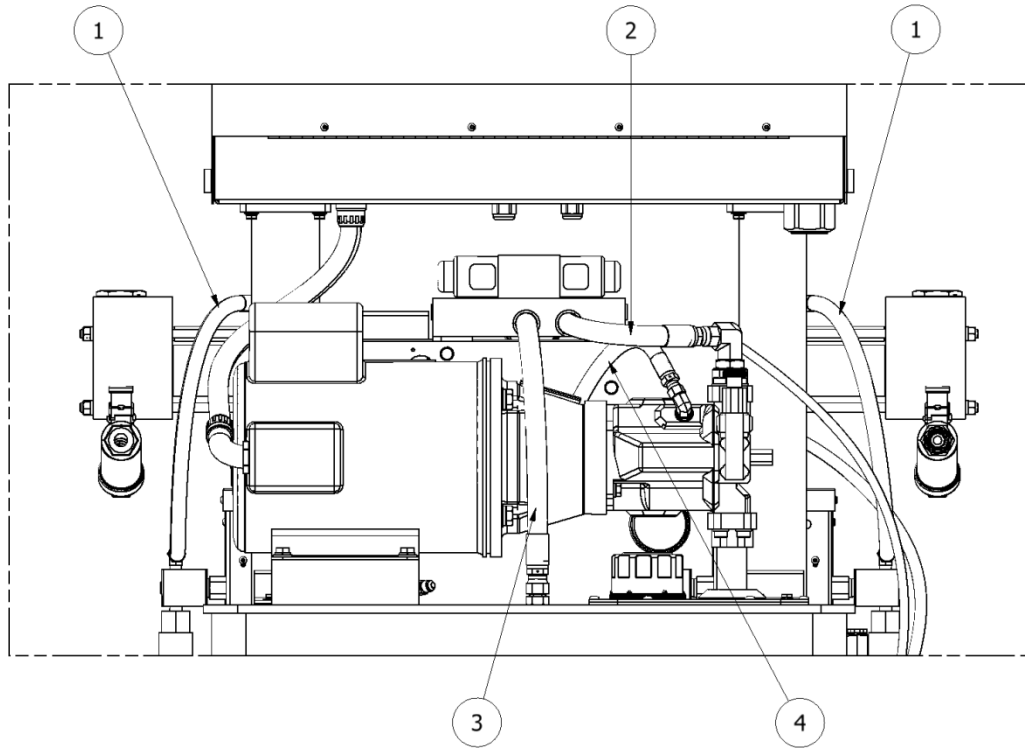

HOSES			
ITEM	QTY	PART NUMBER	DESCRIPTION
1	1	HI-05047	PUMP TO HEATER HOSE
2	2	HI-05014	HYDRAULIC PUMP OUTPUT HOSE 1/2
3	1	HI-05013	HYDRAULIC PUMP RETURN HOSE 1/2
4	1	HI-05052A	HYDRAULIC PUMP DRAIN HOSE 3/8



Classic PH/PHX-25

MANUAL REVISIONS

Revision	Date	Changes	Approved
1.0		Updated entire manual to reflect current PH/PHX-25 Proportioner.	Vadams